



POWERING INNOVATION THAT DRIVES HUMAN ADVANCEMENT

© 2025 ANSYS, Inc. or its affiliated companies  
Unauthorized use, distribution, or duplication is prohibited.

# Getting Started with HFSS™: 20 GHz Waveguide Combiner



ANSYS, Inc.  
Southpointe  
2600 Ansys Drive  
Canonsburg, PA 15317  
[ansysinfo@ansys.com](mailto:ansysinfo@ansys.com)  
<https://www.ansys.com>  
(T) 724-746-3304  
(F) 724-514-9494

Release 2025 R1  
January 2025

ANSYS, Inc. and ANSYS  
Europe, Ltd. are UL registered  
ISO 9001:2015 companies.

## Copyright and Trademark Information

© 1986-2025 ANSYS, Inc. Unauthorized use, distribution or duplication is prohibited.

ANSYS, Ansys Workbench, AUTODYN, CFX, FLUENT and any and all ANSYS, Inc. brand, product, service and feature names, logos and slogans are registered trademarks or trademarks of ANSYS, Inc. or its subsidiaries located in the United States or other countries. ICM CFD is a trademark used by ANSYS, Inc. under license. All other brand, product, service and feature names or trademarks are the property of their respective owners. FLEXIm and FLEXnet are trademarks of Flexera Software LLC.

## Disclaimer Notice

THIS ANSYS SOFTWARE PRODUCT AND PROGRAM DOCUMENTATION INCLUDE TRADE SECRETS AND ARE CONFIDENTIAL AND PROPRIETARY PRODUCTS OF ANSYS, INC., ITS SUBSIDIARIES, OR LICENSORS. The software products and documentation are furnished by ANSYS, Inc., its subsidiaries, or affiliates under a software license agreement that contains provisions concerning non-disclosure, copying, length and nature of use, compliance with exporting laws, warranties, disclaimers, limitations of liability, and remedies, and other provisions. The software products and documentation may be used, disclosed, transferred, or copied only in accordance with the terms and conditions of that software license agreement.

ANSYS, Inc. and ANSYS Europe, Ltd. are UL registered ISO 9001: 2015 companies.

## U.S. Government Rights

For U.S. Government users, except as specifically granted by the ANSYS, Inc. software license agreement, the use, duplication, or disclosure by the United States Government is subject to restrictions stated in the ANSYS, Inc. software license agreement and FAR 12.212 (for non-DOD licenses).

## Third-Party Software

See the legal information in the product help files for the complete Legal Notice for Ansys proprietary software and third-party software. If you are unable to access the Legal Notice, please contact ANSYS, Inc.

## Conventions Used in this Guide

Please take a moment to review how instructions and other useful information are presented in this documentation.

- Procedures are presented as numbered lists. A single bullet indicates that the procedure has only one step.
- Bold type is used for the following:
  - Keyboard entries that should be typed in their entirety exactly as shown. For example, “**copy file1**” means you must type the word **copy**, then type a space, and then type **file1**.
  - On-screen prompts and messages, names of options and text boxes, and menu commands. Menu commands are often separated by greater than signs (>). For example, “click **HFSS > Excitations > Assign > Wave Port.**”
  - Labeled keys on the computer keyboard. For example, “Press **Enter**” means to press the key labeled **Enter**.
- Italic type is used for the following:
  - Emphasis.
  - The titles of publications.
  - Keyboard entries when a name or a variable must be typed in place of the words in italics. For example, “**copy filename**” means you must type the word **copy**, then type a space, and then type the name of the file.
- The plus sign (+) is used between keyboard keys to indicate that you should press the keys at the same time. For example, “Press Shift+F1” means to press the **Shift** key and, while holding it down, press the **F1** key also. You should always depress the modifier key or keys first (for example, Shift, Ctrl, Alt, or Ctrl+Shift), continue to hold it/them down, and then press the last key in the instruction.

**Accessing Commands:** *Ribbons*, *menu bars*, and *shortcut menus* are three methods that can be used to see what commands are available in the application.

- The *Ribbon* occupies the rectangular area at the top of the application window and contains multiple tabs. Each tab has relevant commands that are organized, grouped, and labeled. An example of a typical user interaction is as follows:

"Click **Draw > Line**"



This instruction means that you should click the **Line** command on the **Draw** ribbon tab. An image of the command icon, or a partial view of the ribbon, is often included with the instruction.

- The *menu bar* (located above the ribbon) is a group of the main commands of an application arranged by category such File, Edit, View, Project, etc. An example of a typical user interaction is as follows:

"On the **File** menu, click the **Open Examples** command" means you can click the **File** menu and then click **Open Examples** to launch the dialog box.

- Another alternative is to use the *shortcut menu* that appears when you click the right-mouse button. An example of a typical user interaction is as follows:

"Right-click and select **Assign Excitation > Wave Port**" means when you click the right-mouse button with an object face selected, you can execute the excitation commands from the shortcut menu (and the corresponding sub-menus).

## Getting Help: Ansys Technical Support

For information about Ansys Technical Support, go to the Ansys corporate Support website, <http://www.ansys.com/Support>. You can also contact your Ansys account manager in order to obtain this information.

All Ansys software files are ASCII text and can be sent conveniently by e-mail. When reporting difficulties, it is extremely helpful to include very specific information about what steps were taken or what stages the simulation reached, including software files as applicable. This allows more rapid and effective debugging.

## Help Menu

To access help from the Help menu, click **Help** and select from the menu:

- **[product name] Help** - opens the contents of the help. This help includes the help for the product and its *Getting Started Guides*.
- **[product name] Scripting Help** - opens the contents of the *Scripting Guide*.
- **[product name] Getting Started Guides** - opens a topic that contains links to Getting Started Guides in the help system.

## Context-Sensitive Help

To access help from the user interface, press **F1**. The help specific to the active product (design type) opens.

You can press **F1** while the cursor is pointing at a menu command or while a particular dialog box or dialog box tab is open. In this case, the help page associated with the command or open dialog box is displayed automatically.

# Table of Contents

<b>Table of Contents</b> .....	<b>Contents-1</b>
<b>1 - Introduction</b> .....	<b>1-1</b>
The Sample Problem .....	1-1
Results of Analysis .....	1-2
Overview of the Interface .....	1-2
<b>2 - Creating the New Project</b> .....	<b>2-1</b>
Add the New Project .....	2-1
Insert an HFSS Design .....	2-2
Add Project Notes .....	2-3
Select the Solution Type .....	2-3
Save the Project .....	2-5
<b>3 - Set Up the Drawing Region</b> .....	<b>3-1</b>
Set View Options .....	3-1
Overview of the Modeler Window .....	3-3
Coordinate System Settings .....	3-4
Units Settings .....	3-4
Grid Settings .....	3-5
Transparency Setting .....	3-6
<b>4 - Creating the Model Geometry</b> .....	<b>4-1</b>
Draw the Polyline1 Object .....	4-1
Verify the Points of Polyline1 .....	4-6
Duplicate and Mirror Polyline1 .....	4-10
Unite Polyline1 and Polyline1_1 .....	4-12
Modify the Waveguide's Attributes .....	4-13
Rename Polyline1 .....	4-14
Assign a Color to the Waveguide .....	4-14
Assign a Transparency to the Waveguide .....	4-14
Verify that Lighting Is Enabled and Using Default Attributes .....	4-15

---

Sweep the Waveguide .....	4-16
<b>5 - Setting Up the Problem .....</b>	<b>5-1</b>
Set Up Boundaries and Excitations .....	5-1
Boundary Conditions .....	5-1
Assign Boundaries .....	5-2
Assign a Finite Conductivity Boundary to the Bottom and Side Faces .....	5-2
Assign a Perfect E Symmetry Boundary to the Top Face .....	5-7
Excitation Conditions .....	5-11
Assign Excitations .....	5-11
Assign Wave Port 1 .....	5-13
Assign Wave Port 3 .....	5-14
Assign Wave Port 2 .....	5-15
Assign Wave Port 4 .....	5-17
Verify All Boundary and Excitation Assignments .....	5-19
<b>6 - Set up and Generate a Solution .....</b>	<b>6-1</b>
Specify Solution Options .....	6-1
Add a Solution Setup .....	6-1
Add a Frequency Sweep .....	6-5
Validate the Project Setup .....	6-7
Generating the Solution .....	6-8
Analyze the Setup You Defined .....	6-9
View the Solution Data .....	6-10
View the Profile Data .....	6-10
View the Convergence Data .....	6-11
View the Matrix Data .....	6-13
<b>7 - Analyzing the Solution .....</b>	<b>7-1</b>
Create an S-Parameters Report of S11, S12, S13, and S14 .....	7-1
Create an S-Parameters Report of S12 and S14 .....	7-3
Scale the Magnitude and Phase for the Ports .....	7-5
Create a Mag E Field Overlay .....	7-6

---

---

Create a Phase Animation of the Mag E Overlay .....	7-8
Self-Study Challenge .....	7-10
<b>8 - Optionally, Restore Legacy View Orientations .....</b>	<b>8-1</b>



# 1 - Introduction

This *Getting Started* guide describes how to set up and solve a two-way, low-loss waveguide combiner.

By following the steps in this guide, you will learn how to perform the following tasks in HFSS:

- Draw a geometric model.
- Modify a model's design parameters.
- Assign variables to a model's design parameters.
- Specify solution settings for a design.
- Validate a design setup.
- Run an HFSS simulation.
- Create plots and a field overlay of the results (see [Results of Analysis](#)).

## The Sample Problem

For this problem, the waveguide combiner is a standard WR42 model with a four-port combining junction. Each waveguide is 420 mils wide and 170 mils high. This type of waveguide combiner is used to combine the output power of two 20 GHz solid state power amplifiers (SSPA) with a very compact size and low insertion loss.

The outputs of the SSPAs are fed into Ports 2 and 4 of the waveguide with a 90-degree out-of-phase separation to steer the output power of the amplifiers to port 1. Port 3 of the waveguide is the isolated port where the impedance mismatch at the output (port 1) is absorbed.

This problem is also described and analyzed in the following reference:

Arcioni, Paolo, Perregrini, Luca, Bonecchi, Fulvio, "Low-Loss Waveguide Combiners for Multidevice Power Amplifiers," *The Second International Conference on Electromagnetics in Aerospace Applications*, September 1991.

The geometry for this waveguide combiner problem is shown below:

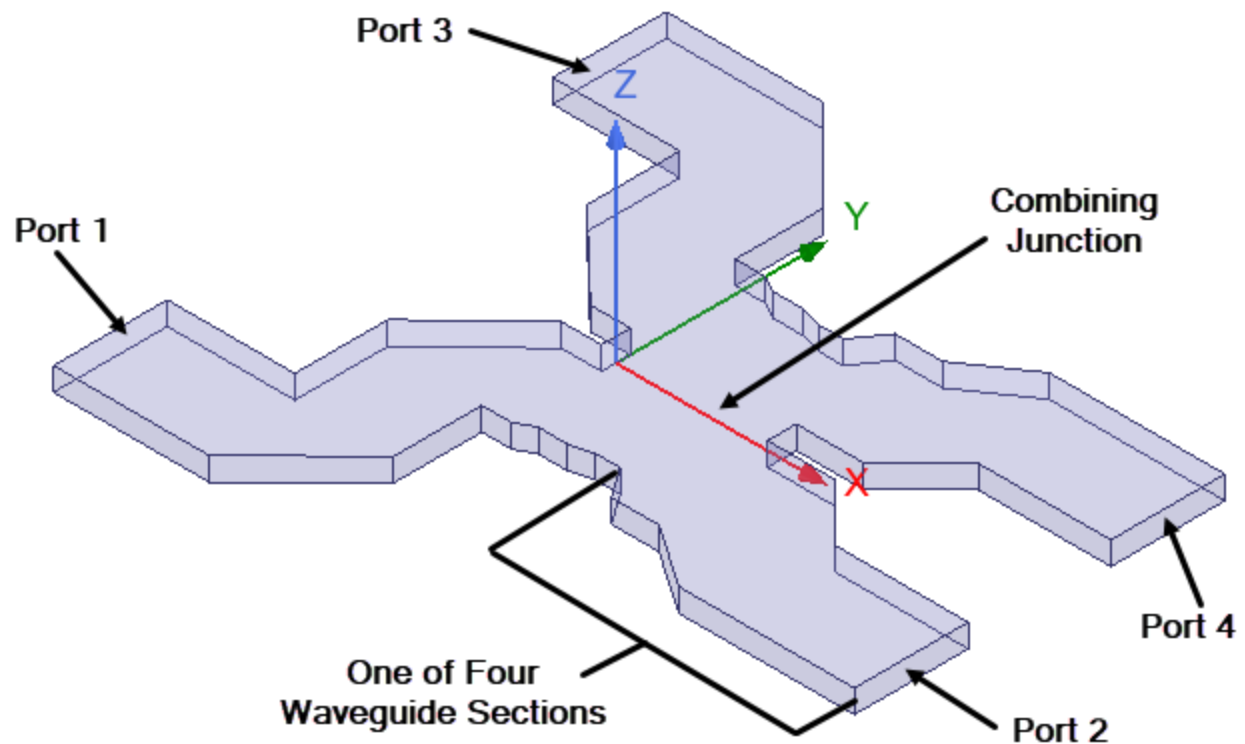

## Results of Analysis

After setting up the waveguide combiner model and generating a solution, you will:

- Create Modal S-parameter reports (2D x-y plot).
- Create a field overlay of the E-field magnitude.
- Create an animation of the E-field magnitude overlay.

## Overview of the Interface

Below is an overview of the major components of the HFSS interface.

### Note:

The background color can be changed from **View > Modify Attributes > Background Color**.

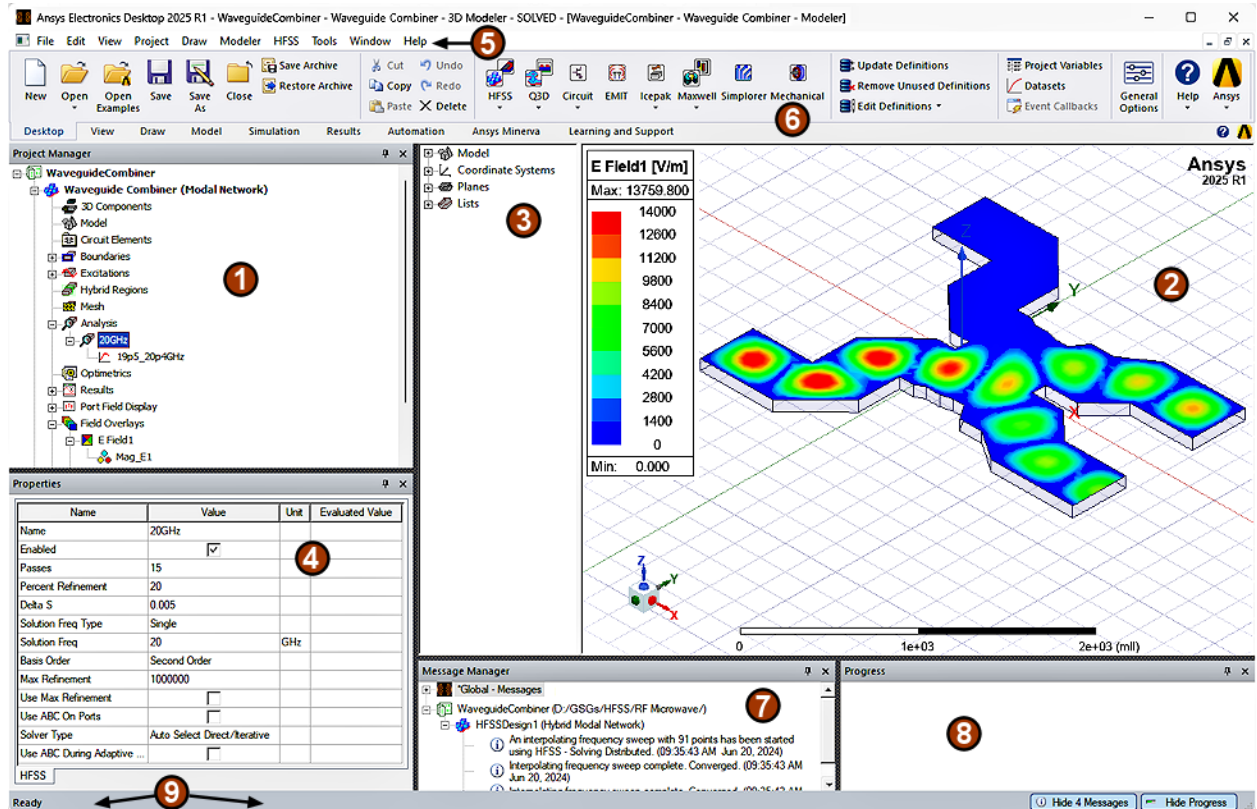

<p><b>1: Project Manager Window</b></p>	<p>Displays details about all open HFSS projects. Each project has its own <i>project tree</i>, which ultimately includes one or more designs, each with a geometric model and its boundaries and excitations, material assignments, analysis setups, and results.</p>
<p><b>2: Modeler Window</b></p>	<p>Displays the drawing area of the active model, along with the History Tree.</p>
<p><b>3: History Tree</b></p>	<p>Lists all objects comprising the active design, grouped by the object type and material assignment. It also contains the history of all operations carried out on the model. Defined planes, points, coordinate systems, and object/face lists are also contained in the History Tree.</p>

<b>4: Properties Window</b>	<p>Displays the attributes of a selected object in the active model (such as the object's name, material assignment, orientation, color, and transparency). You can directly modify the specified attributes within this window.</p> <p>Also displays information about a selected command that has been carried out. For example, if a circle was drawn, its command information would include the command's name, the coordinate system used to define it, the circle's center position coordinates, the axis about which the circle was drawn, and its radius.</p> <p>You can directly modify the specified attributes that are listed within this window.</p>
<b>5: Menu Bar</b>	<p>Provides various menus that enable you to perform all of the HFSS tasks, such as managing project files, customizing the desktop components, drawing objects, assigning boundaries and excitations, setting and modifying all project parameters, and creating reports.</p>
<b>6: Ribbon</b>	<p>Provides commonly used commands organized into separate tabs, panels, and drop-down menus, many of which are represented with icons.</p>
<b>7: Message Manager Window</b>	<p>Displays error, informational, and warning messages for the active project and its solution.</p>
<b>8: Progress Window</b>	<p>Displays a progress bar and solution information while performing the analysis.</p>
<b>9: Status Bar</b>	<p>Shows current status or required actions and provides instructional prompts.</p> <p>In addition, depending on the command being carried out, the status bar can display the X, Y, and Z coordinate boxes, the <b>Absolute/Relative</b> pull-down list to enter a point's absolute or relative coordinates, a drop-down list to specify a point in Cartesian, Cylindrical, or Spherical Coordinates, and the active model's length units.</p>

## 2 - Creating the New Project

Your goals in this chapter are as follows:

- Create a new project.
- Add an HFSS design to the project.
- Optionally add project notes.
- Select the Solution Type
- Save the project with a user-specified name.

This chapter describes how to create a project in which to save all the data associated with the problem. By default, when you launch the Ansys Electronics Desktop a new project named *Projectn* is automatically created into which you can insert a new HFSS design.



You can also create a new project and insert a design manually.

### Time



It should take you approximately 10 minutes to work through this chapter.



## Add the New Project

1. Launch the Electronics Desktop application, if it is not already running.
2. If you have just started Electronics Desktop, a new project has already been created for you automatically. You can skip this step. However, if you previously opened Electronics Desktop and then closed the project you had been working on, do one of the following to create a new project:
  - From the menu bar, click **File > New**.
  - From the **Desktop** tab of the ribbon, click  **New**.

A new project is listed at the top of the **Project Manager** window. It is named *Projectn* by default, where *n* is a serial number incremented from the highest existing *Projectn* file already in the default project folder. Project definitions, such as boundaries and material assignments, are stored under the project name shown in the Project Manager.

## Insert an HFSS Design

The next step for this waveguide combiner problem is to insert an HFSS design into the new project. On adding an HFSS design type, a design named HFSSDesign*n* with the solution type as [Driven Modal] appears for the current project. You will change that default design name to something more descriptive.

3. Select the project name (**Project*n***) at the top of the **Project Manager** window.
4. To manually insert an HFSS design into the project, do one of the following:
  - Using the menu bar, click **Project > Insert HFSS Design**.
  - Right-click the project name in the **Project Manager** window, and then select **Insert > Insert HFSS Design** from the shortcut menu.
  - In the **Desktop** tab of the ribbon, click  **Insert HFSS Design**.
  - In the **Desktop** tab of the ribbon, choose  **HFSS** from the **Insert HFSS Design** drop-down menu.

An **HFSS Design** icon and heading are added to the Project Manager.

5. Select **HFSSDesign1** and press **F2** to rename the design. Then,
  - a. Type **Waveguide Combiner**, replacing the default name.

Spaces are permitted within design names. Since this project will only include a single design, this name is sufficiently descriptive. When a project contains multiple designs, it's a good practice to specify names that clearly differentiate them and make the purpose of each design clear.

- b. Press **Enter**.

The design within the Project Manager should now look like the following image:

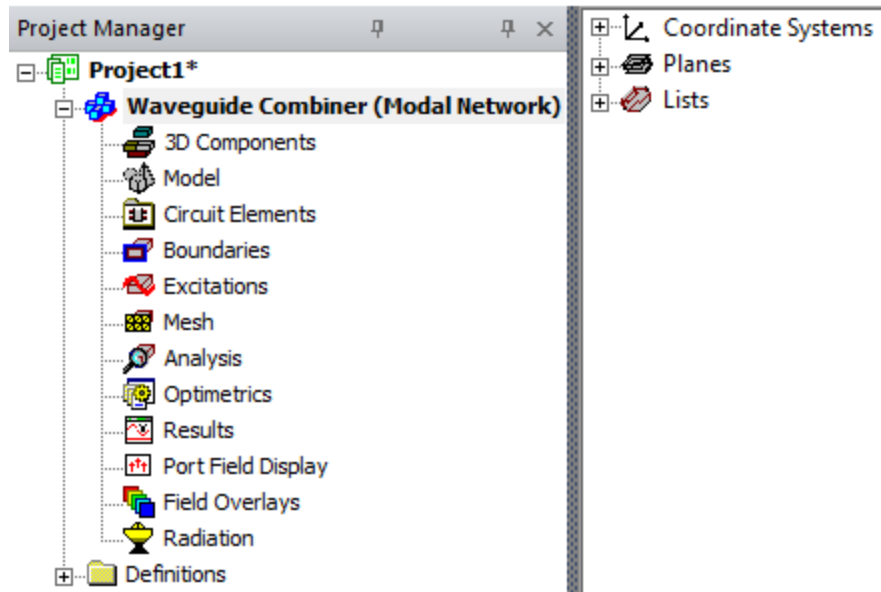

## Add Project Notes

Optionally, you can enter notes about your project, such as its creation date and a description of the device being modeled. These notes are useful for keeping a running log of the project details and for future reference.

To add notes to the project:

1. In the Project Manager, right-click the HFSS design heading, **Waveguide Combiner ( ... )**, and select **Edit Notes** from the shortcut menu.

The **Design Notes** window appears.

2. Click inside the window and type your notes, such as a description of the model, assumed conditions, and the software version in which it is being created.
3. Click **OK** to save the notes with the current project.

### Note:

To edit existing project notes, double-click **Notes** in the Project Manager. The **Design Notes** window appears, and you can edit its content as needed.

## Select the Solution Type

Before you draw the geometry, specify a solution type as follows:

1. Access the **Solution Type** dialog box using one of the following two methods:
  - Using the menu bar, click **HFSS > Solution Type**.
  - In the Project Manager, right-click **Waveguide Combiner ( ... )** and choose **Solution Type** from the shortcut menu.

The *Solution Type* dialog box appears.

2. Under **Options**, choose **Modal**.

The **Solution Type** should be **HFSS**, and also, **Network Analysis** should be selected under **Options**:

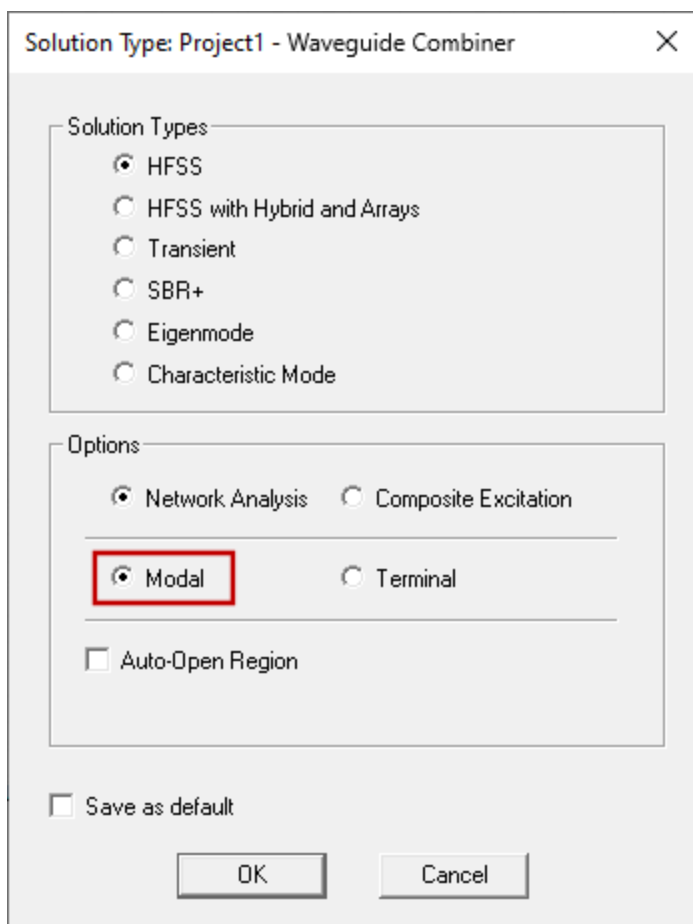

Some of the possible solution types and options are described below:

<b>Modal</b>	For <i>HFSS</i> or <i>HFSS with Hybrid and Array</i> solutions only. This option calculates the mode-based S-parameters of passive, high-frequency structures such as microstrips, waveguides, and transmission lines, which are “driven” by a source.
<b>Terminal</b>	For <i>HFSS</i> or <i>HFSS with Hybrid and Array</i> solutions only. This option cal-

	<p>calculates the terminal-based S-parameters of passive, high-frequency structures with multi-conductor transmission line ports, which are “driven” by a source.</p> <p>The solution produces terminal-based results related to voltages and currents.</p>
<b>Eigenmode</b>	<p>Calculates the eigenmodes, or resonances, of a structure. The Eigenmode solver finds the resonant frequencies of the structure and the fields at those resonant frequencies.</p>

3. Click **OK** to apply the **Modal** solution type to your design.

## Save the Project

Next, save and name the new project.

It is important to save your project frequently to prevent loss of your work if a problem occurs.

### Note:

By default, Ansys Electronics Desktop autosaves your projects every ten edits. Auto-save settings are found in the **General > Desktop Configuration** section of the General Options. You can change the autosave interval or disable the feature.

To save the new project:

1. From the menu bar, click **File > Save As**.

The *Save As* dialog box appears.

2. Use the file browser to find the directory where you want to save the file.
3. Type the name **WaveguideCombiner** in the **File name** text box.

The filename will also be used as the project name, replacing "Project*n*."

While spaces are permitted within file and project names, it is convenient to avoid using them. When a path/filename contains spaces, it must be enclosed in quotation marks within system commands and batch commands. It is not necessary to do so when no spaces are present because the operating system can clearly identify the command name, path/filename, and optional parameters.

**Note:**

In an earlier step, you changed the HFSS design name to *Waveguide Combiner*. It may seem redundant to have nearly identical project and design names, but there is a reason for doing so. Reports that you add to the project, such as an S-Parameter plot, will be labeled with the design name by default. However, the project name is not included on the report. It is a good practice to specify descriptive project and design names. The same guideline applies to analysis setup names, sweep names, and more.

4. In the **Save as type** list, accept **Ansys Electronics Desktop Project File (\*.aedt)** as the correct file type.

When you create an HFSS project, it is given an *aedt* filename extension by default and placed in the project directory. Any files and subfolders related to that project are stored in the same directory.

5. Click **Save**.

The project is saved to the specified location.

**Note:**

For more information on any topic in HFSS, such as coordinate systems and grids or *Modeler* commands or windows, you can view the context-sensitive help:

- Click the **Help** button in a pop-up window.
- Press **F1**. This opens the Help window. If you have a dialog open, or if the cursor is pointing at a menu command, your browser opens to a page that describes the dialog box or command (context-sensitive help).
- Use the commands from the **Help** menu.

At this point you are ready to set up the drawing region in preparation for drawing the waveguide combiner.

## 3 - Set Up the Drawing Region

The next step is to set up the drawing region.

In this chapter, you will:

- Enable Legacy View Orientations
- Look at an overview of the *Modeler* window
- Learn about settings for the following four items:
  - Coordinate System
  - Units
  - Grid
  - Transparency

For this waveguide combiner problem, use the default coordinate system, specify the units, and define the grid settings.

### Set View Options

This getting started guide has been updated to use the new standard view orientations that were implemented in version 2024 R1 of the Ansys Electronics Desktop application. For consistency between your experience and the views and instructions contained in this guide, ensure that the *Enable Legacy View Orientation* option in the *3D UI Options* dialog box is **cleared**, as follows:

1. From the menu bar, click **View > Options**.

The *3D UI Options* dialog box appears.

2. Clear **Enable Legacy View Orientation** if the option is selected:

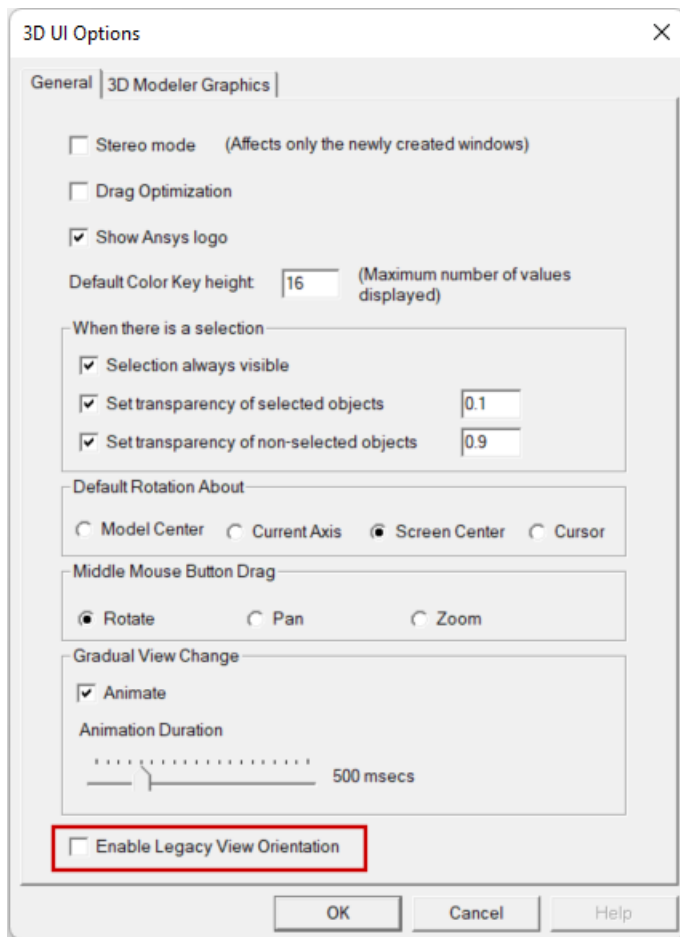

3. Click **OK**.

Changing the view orientation option does not change the model viewpoint that was in effect at the time.

4. On the **Draw** ribbon tab, click **Orient** to ensure that you are looking at the *Isometric* view, which is the current default view orientation.

You do not have to select *Isometric* from the *Orient* drop-down menu. The default view appears when you click *Orient*.

Although the *Enable Legacy View Orientation* option can only be accessed once a design is added to a project, it is a global option. Your choice is retained for all future program sessions, projects, and design types that use the 3D Modeler or that produce 3D plots of results.

At the end of this guide, you will be prompted to restore your preference, if you prefer to continue using the legacy view orientations that were in effect for 2023 R2 and earlier versions of the software.

For a comparison of the legacy and current view orientations, search for "*View Options: 3D UI Options*" in the HFSS help. Additionally, views associated with **Alt + double-click** zones have

been redefined. The current orientations are shown in the help topic, "[Changing the Model View with Alt+Double-Click Areas.](#)"

## Overview of the Modeler Window

The area containing the model is called the *drawing region*. Models are drawn in the *Modeler* window, which appears in the desktop after you insert a design into the project.

As shown below, the *Modeler* window consists of a Grid, coordinate axes, a scale indicator (Ruler), a View Orientation Gadget, and a History Tree. The view orientation gadget provides a convenient alternative for manipulating the model viewpoint, as opposed to using the menu bar, ribbon commands, or other mouse actions. The grid is an aid to help visualize the location and size of objects. For more information about the grid, see "[Grid Settings.](#)"

The History Tree displays all operations and commands carried out on the active model. See "[HistoryTree](#)" for more information.

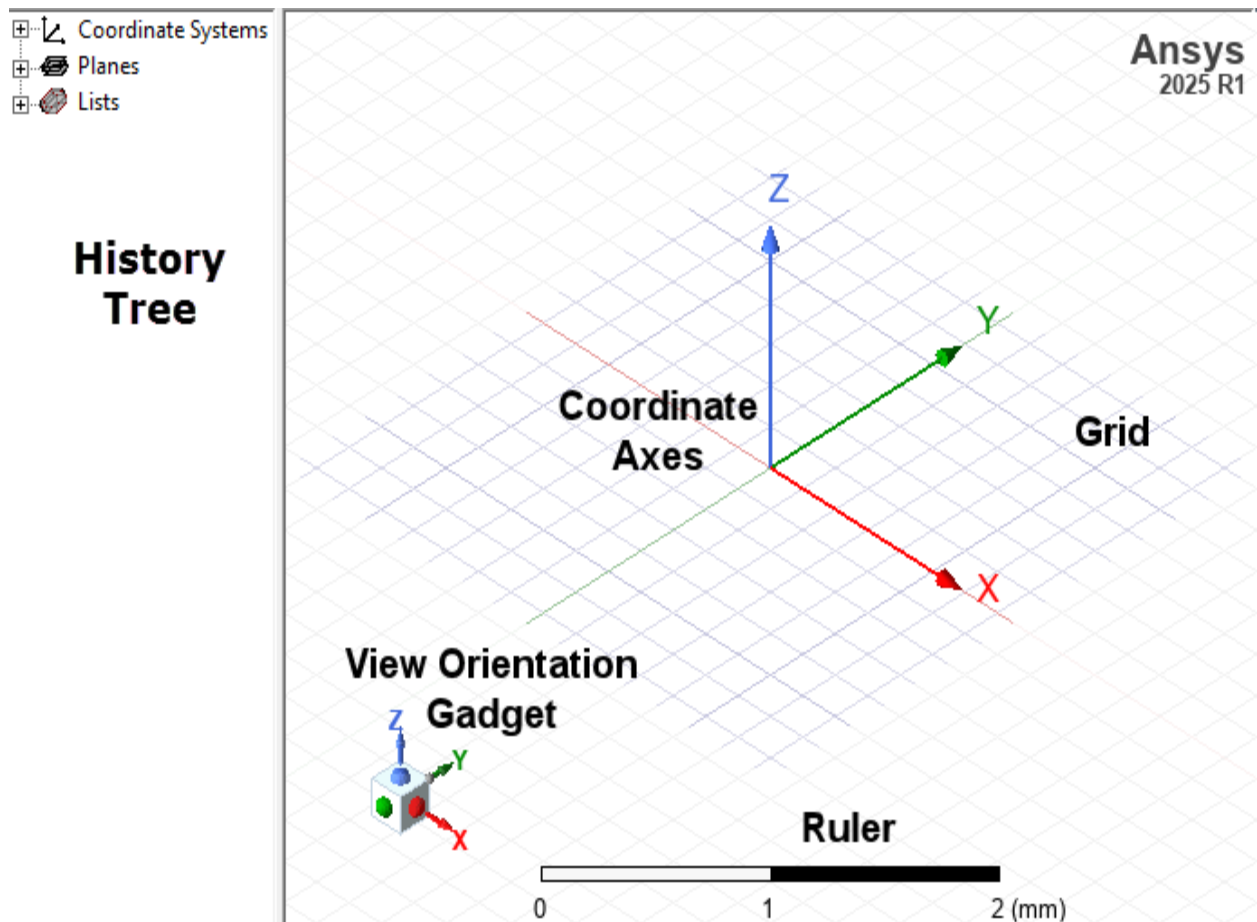

## Coordinate System Settings

For this waveguide combiner problem, use the fixed, default global coordinate system (CS) as the working CS. This is the current CS with which objects being drawn are associated.

HFSS has three types of coordinate systems that let you easily orient new objects: a *global* coordinate system, a *relative* coordinate system, and a *face* coordinate system. Each of these coordinate systems has an X-axis that lies at a right angle to a Y-axis, and a Z-axis that is normal to the XY plane. The origin (0,0,0) of every CS is located at the intersection of the X-, Y-, and Z-axes.

<b>Global CS</b>	The fixed, default CS for each new project. It cannot be edited or deleted.
<b>Relative CS</b>	A user-defined CS. Its origin and orientation can be set relative to the global CS, relative to another relative CS, or relative to a geometric feature. Relative CS enables you to easily draw objects that are located relative to other objects.
<b>Face CS</b>	A user-defined CS. Its origin is specified on a planar object face. Face CS enables you to easily draw objects that are located relative to an object's face.

## Units Settings

Specify the drawing units for your model. For this waveguide combiner problem, set the drawing units to mils (also known as milli-inches; 1 mil = 0.001 inch).

To set the drawing units:

1. Access the *Set Model Units and Max Extent* dialog box using one of the following two methods:
  - Using the menu bar, click **Modeler > Units**.
  - From the **Draw** tab of the ribbon, click **Units**.
2. Select **mil** from the **Select units** drop-down menu and ensure **Rescale to new units** is cleared. Also, leave the **Advanced** option cleared, keeping the default model extents of +/-10000 length units.

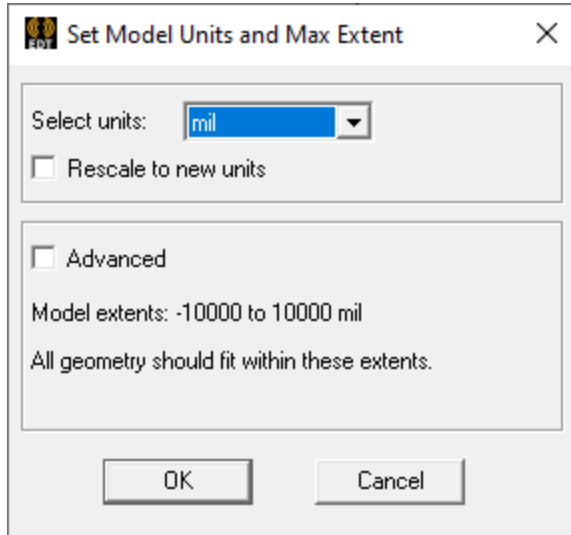
**Note:**

- When **Rescale to new units** is *not* selected, the dimensions of any existing geometry are updated to keep the size and location of the objects unchanged. For example, a 1 inch cube would become an equivalent 25.4 mm cube when changing units from inch to mm.
- When **Rescale to new units** is *selected*, the numerical values of any existing dimensions remain unchanged, but the units are redefined. This process changes the physical size and location of the previously drawn objects. For example, a 1 inch cube with its lower left corner placed 1 inch in the +X direction from the origin would become a 1 mm cube placed 1 mm from the origin. Use this option to correct objects drawn using the correct numerical values but the wrong units setting.
- In either case, the grid spacing is adjusted to reflect the new units.

3. Click **OK** to accept mils (thousandths of an inch) as the length unit for drawing this model.

## Grid Settings

The grid displayed in the *Modeler* window is a drawing aid that helps to visualize the location and size of objects. In addition, the cursor can snap to grid points when drawing objects graphically, depending on the settings under **3D Modeler > Snap** in the General Options. The points on the grid are divided by their local x-, y-, and z-coordinates, and grid spacing is set according to the current project's drawing units.

To edit the grid's properties, click **Grid Settings** on the **View** menu. You can control the grid type (Cartesian or polar), style (dots or lines), density, spacing, or visibility.

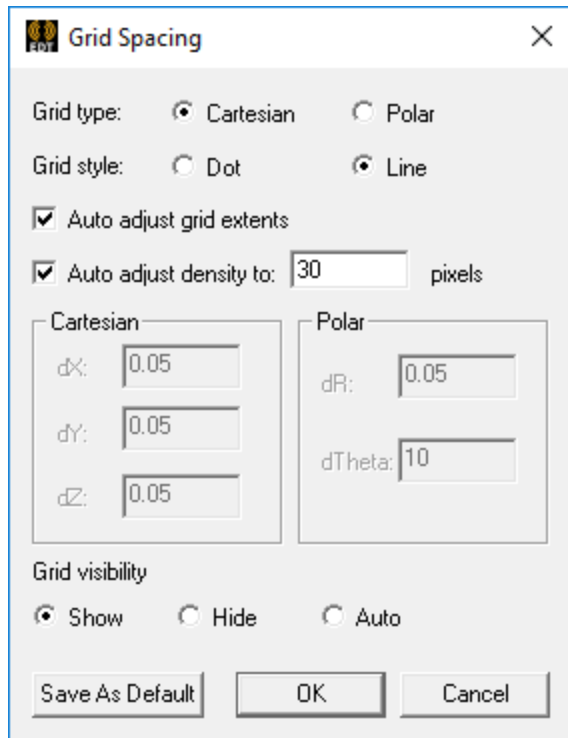

For this waveguide combiner project, it is not necessary to edit any of the grid's default properties.

## Transparency Setting

Set the default transparency for objects to 0.4.

To set the default transparency for new objects:

1. Access the *Options* dialog box using one of the following two methods:
  - From the menu bar, click **Tools > Options > General Options**.
  - In the **Desktop** tab of the ribbon, click  **General Options**.
2. In the options tree, expand the **3D Modeler** branch and the **Display** sub-branch. Then, click **Rendering**.
3. Change the **Default transparency** to **0.4**.

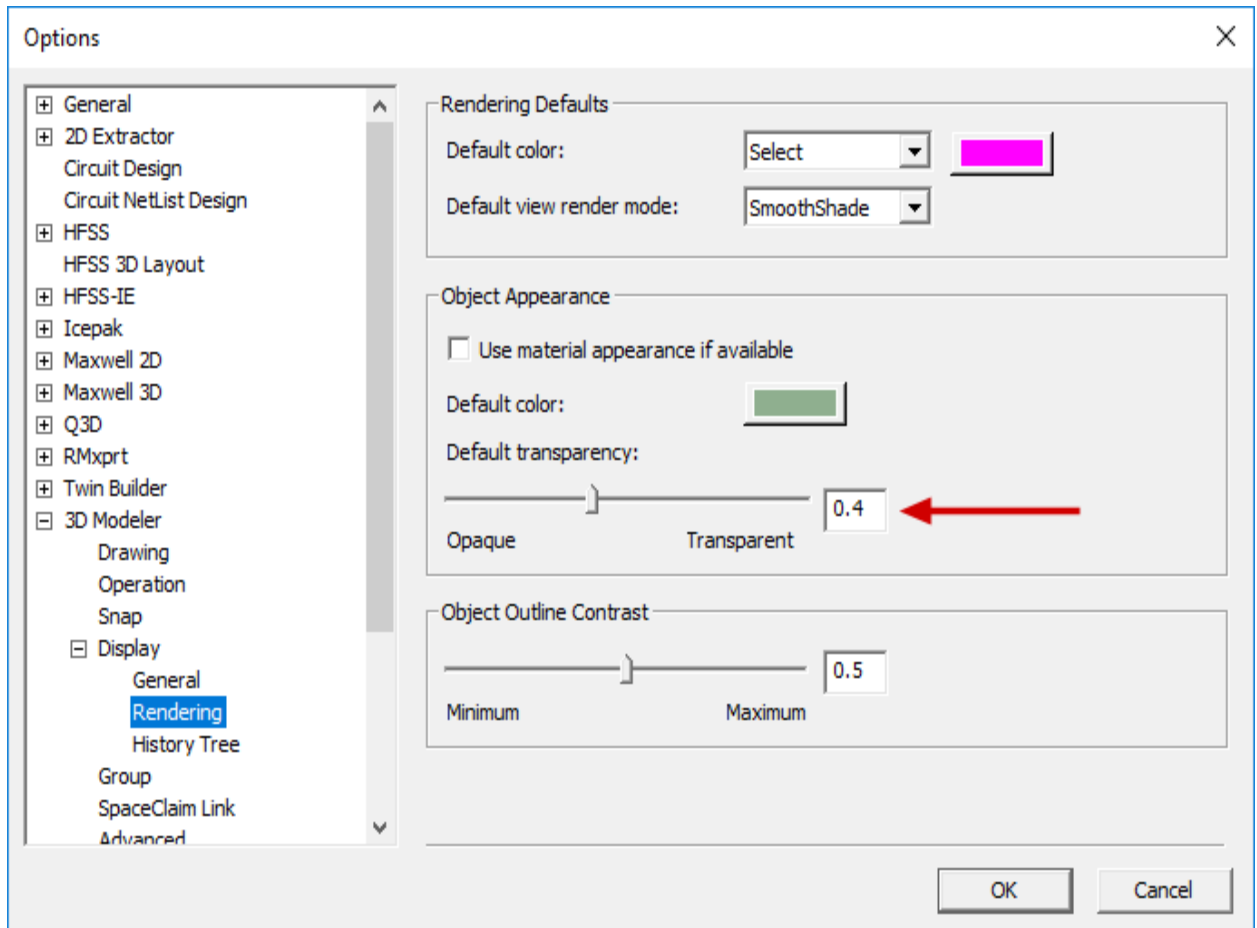

4. Click **OK**.

## 4 - Creating the Model Geometry

This chapter shows you how to create the geometry for the waveguide combiner problem described earlier. Your goals are as follows:

- Drawing the objects that make up the waveguide combiner.
- Assigning color and transparency to the objects.
- Assigning materials to the objects.

The geometry for this model consists of a single standard WR42 waveguide combiner object with a four-port, low-loss combining junction. Each waveguide is 420 mils wide and 170 mils high.

The waveguide combiner starts out as a 2D sheet object (a geometric object containing surface area but no volume). You draw the sheet object on the XY plane as a series of polylines enclosing an area. Since this model is symmetrical about the XZ plane, just draw the left-half of the structure's outline. Then, complete the outline of the sheet object by duplicating and mirroring the left side to create the right side. Finally, merge (that is, Union) the two sides together.

Create the 3D waveguide combiner by sweeping the 2D sheet object in the Z direction. To reduce the size of this model, only sweep the outline half of its actual height (170 mils / 2 = 85 mils). Assign a perfect E symmetry boundary to the top face of the waveguide combiner to represent the other (unmodeled) half of the device. This technique reduces the mesh volume to half that of the full model, thereby shortening the solution time.

For a detailed description about this waveguide combiner, see [“The Sample Problem”](#).

You are all set to draw the geometry.

### Time



It should take you approximately 30 minutes to work through this chapter.

## Draw the Polyline1 Object

The first object to be drawn is the left half of the waveguide combiner. Do this by drawing a closed polyline object consisting of 24 unique points and therefore 24 line segments. While you will specify 25 points, the first and last are identical. That is, the path ends on its starting point. This procedure results in a 2D sheet object with a default name of Polyline1.

To draw Polyline1, enter the point coordinates in sequence for each vertex of the 24 polyline segments while creating them.

1. From the menu bar, click **Draw > Line** or, on the **Draw** ribbon tab, click  **Draw line**.

The status bar now prompts you to enter the first point of the polyline.

- Press **Tab** to move to the **X** text box along the bottom of the program window. Then, specify the first point of the line by typing the following X, Y, and Z values, pressing **Tab** to jump to the next coordinate text box. (You can also press **Shift+Tab** to jump to the previous text box.):

Point	X Coordinate	Y Coordinate	Z Coordinate
1	0	0	0

### Important:

- Keep your hand off of the mouse when tabbing into the coordinate text boxes and be very careful *not* to bump the mouse while typing the coordinates. Any mouse movement will cause the numerical values to revert to the graphical location of the cursor and can cause the input mode to change from Absolute to Relative.
- Ensure that the drop-down menu to the right of the coordinate text boxes is set to **Absolute** for the first point and for all subsequent points:

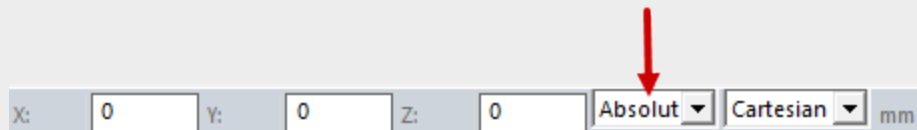

If you move the mouse after typing the first set of coordinates, the input mode will automatically switch to *Relative* for subsequent points. After resetting it to **Absolute**, the setting will remain unchanged for the duration of the *Line* command, despite further mouse movements.

- Press **Enter** to accept the first point.
- Continue with this same method and carefully enter the 24 points that remain, as listed in the table below.

To keep track of the points you are entering, closely observe the **Position1** and **Position2** values in the *Measure Data* window. After typing the coordinates for the next point (but not pressing Enter yet), **Position1** will still report the previous point that you defined, and **Position2** will show the coordinates of the point currently being defined:

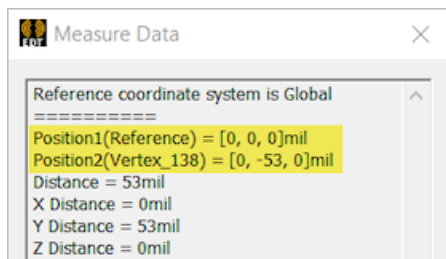

As soon as you press Enter, both **Position1** and **Position2** will report the coordinates of the point just defined:

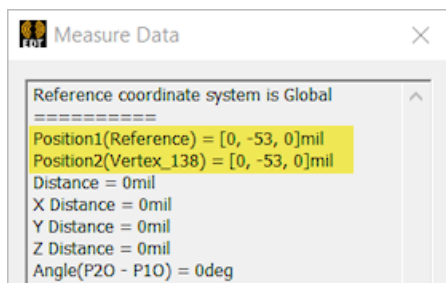

**Note:**

If you accidentally enter an incorrect set of coordinates, you can delete the last point you entered by right-clicking in the *Modeler* window and then clicking **Undo Previous Segment** on the shortcut menu.

Point	X Coordinate	Y Coordinate	Z Coordinate
2	0	-53	0
3	-147	-53	0
4	-474	-367	0
5	-474	-710	0
6	-944	-710	0
7	-944	-1130	0
8	-369	-1130	0
9	-27	-792	0
10	-27	-467	0
11	83	-467	0
12	146	-433	0
13	255	-433	0
14	337	-411	0
15	427	-411	0
16	506	-523	0
17	682	-523	0
18	915	-683	0
19	1562	-683	0
20	1562	-263	0
21	1073	-263	0
22	858	-53	0
23	612	-53	0
24	612	0	0
25	0	0	0

5. Right-click in the *Modeler* window, and click **Close Polyline** on the shortcut menu.

A sheet object appears in the History tree, the object is shaded (selected) in the drawing region, and the *Properties* dialog box appears (if configured to do so when new primitives are created).

**Note:**

Objects are automatically selected immediately after being drawn so that you can instantly view the default attributes and optionally modify them.

6. The object is named Polyline1 by default, as displayed in the **Attributes** tab of the docked *Properties* window and the *Properties* dialog box (if it appears).

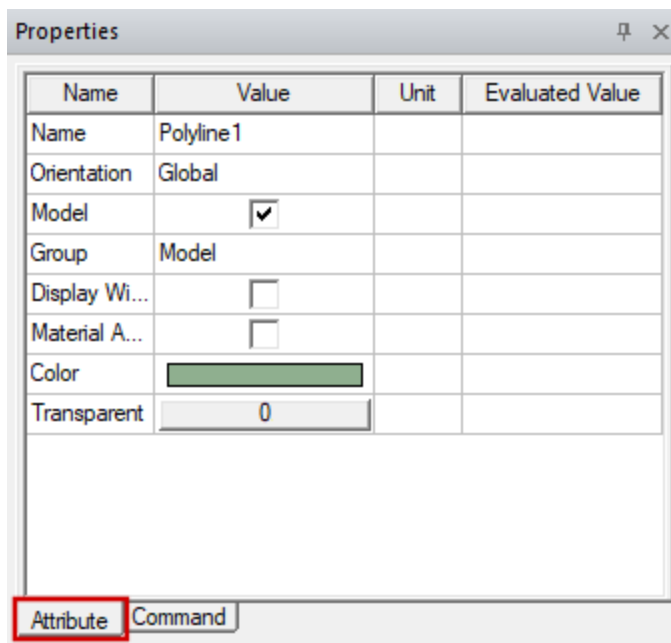

7. Click **OK** to dismiss the *Properties* dialog box if it appears.
8. Press **Ctrl+D** to fit the object in the drawing region.

The completed left-half of the waveguide combiner should appear in the *Modeler* window, as shown below:

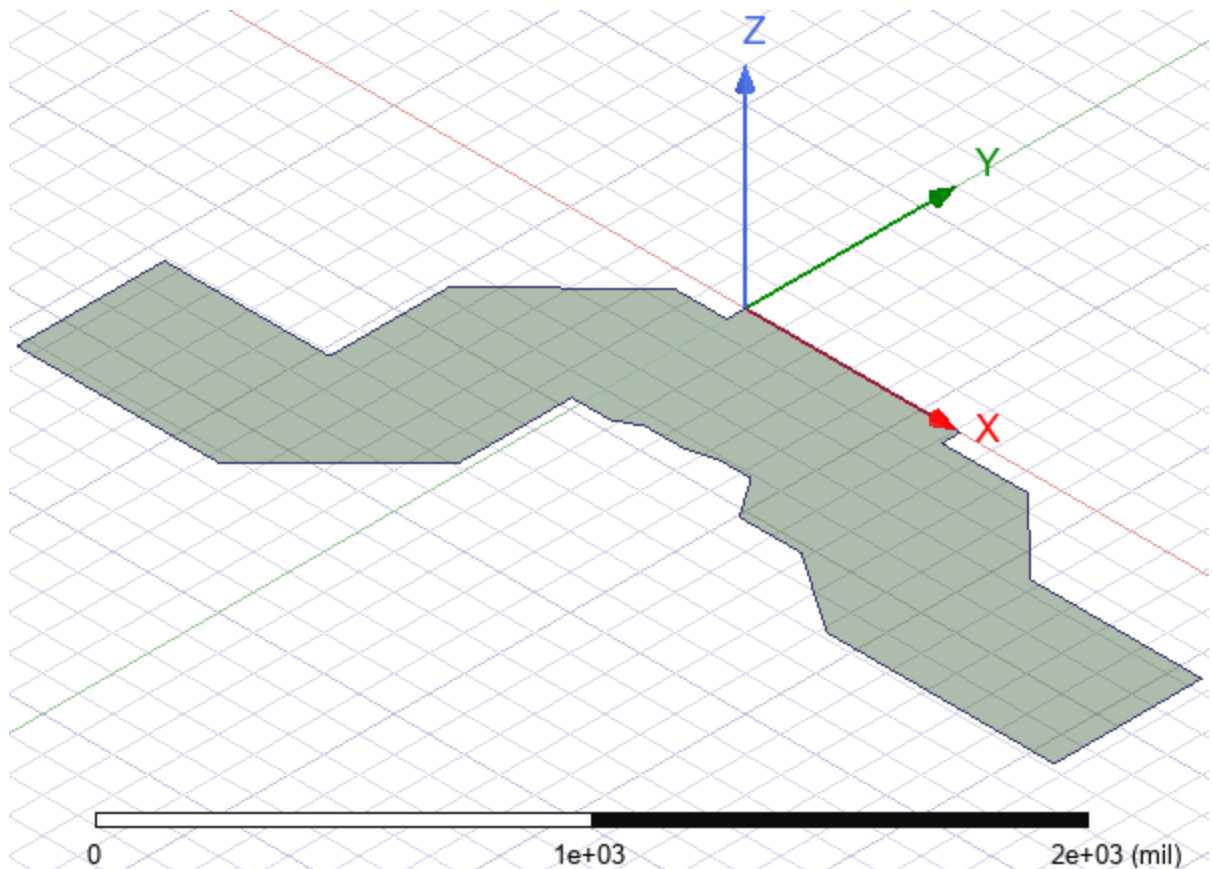

If the appearance of the model is not as shown, proceed to the next step, where you will verify the coordinates of each line segment.

## Verify the Points of Polyline1

Before you duplicate and mirror the object **Polyline1** to create the right-side of the waveguide combiner, it is important that you make sure all the points you entered are correct. You will not obtain the expected simulation results if the geometry is not exactly as described in this exercise.

The image below shows all the point locations used to define the segments for the object **Polyline1**:

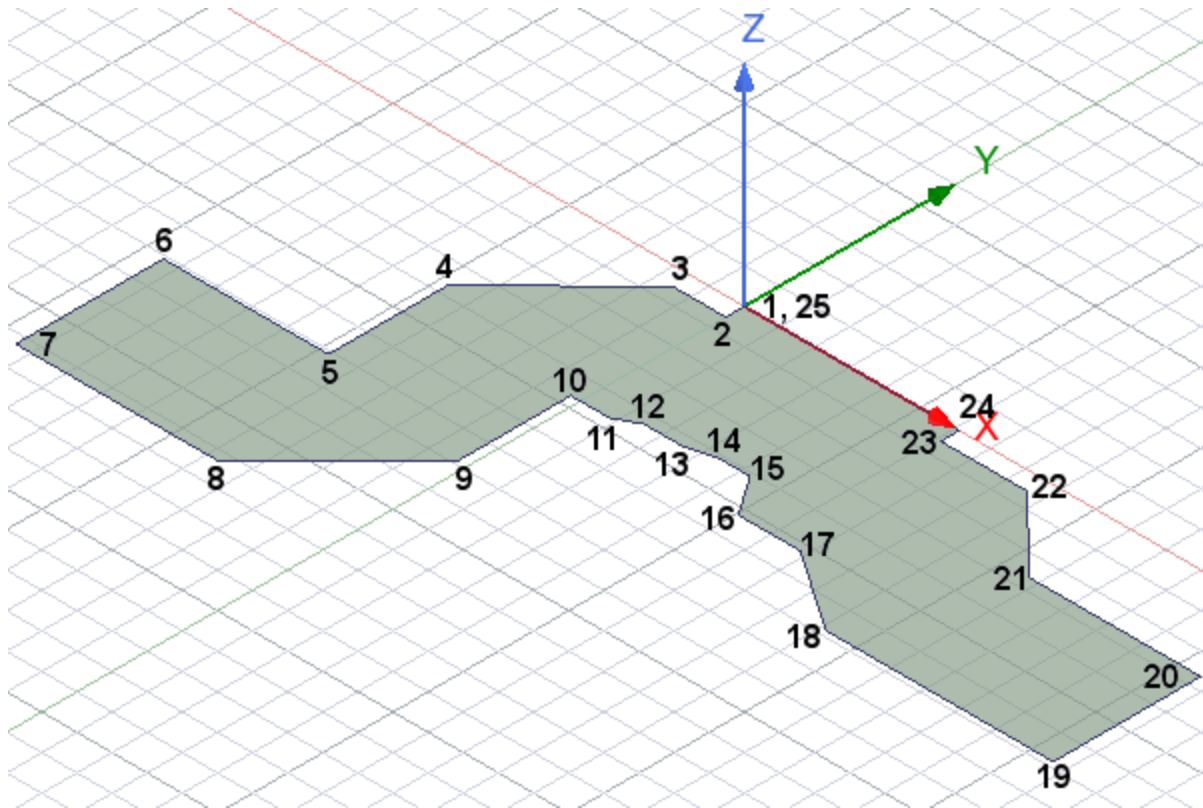

To verify the points:

1. In the History Tree, click the plus (+) symbol to the left of **Sheets** to expand the tree structure to see **Unassigned**. Expand the structure under **Unassigned** to see **Polyline1**. Expand the structure under **Polyline1** to see **Create Polyline**. Expand the structure under **Polyline1** to see 24 **CreateLine** commands under **CreatePolyline**.

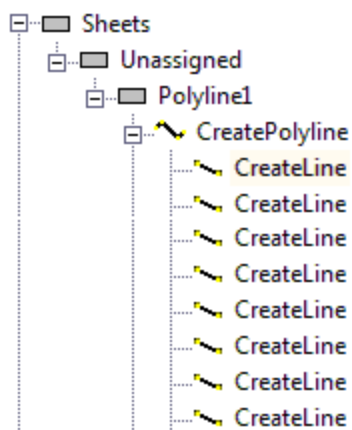

2. Click the first **CreateLine** object in the list to view the coordinate values that you entered for point 1 (0, 0, 0) and point 2 (0, -53, 0).

These values are displayed in the docked *Properties* window, as shown below:

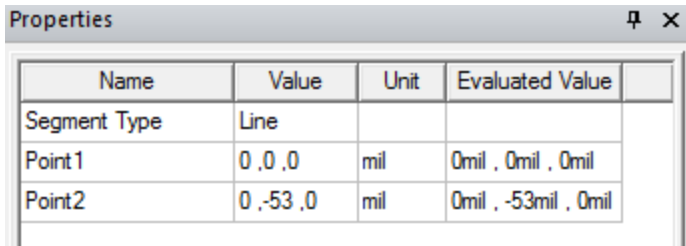

Name	Value	Unit	Evaluated Value
Segment Type	Line		
Point1	0,0,0	mil	0mil, 0mil, 0mil
Point2	0,-53,0	mil	0mil, -53mil, 0mil

3. Verify that the values for these points are correct.

Point	X Coordinate	Y Coordinate	Z Coordinate
1	0	0	0
2	0	-53	0
3	-147	-53	0
4	-474	-367	0
5	-474	-710	0
6	-944	-710	0
7	-944	-1130	0
8	-369	-1130	0
9	-27	-792	0
10	-27	-467	0
11	83	-467	0
12	146	-433	0
13	255	-433	0
14	337	-411	0
15	427	-411	0
16	506	-523	0
17	682	-523	0
18	915	-683	0
19	1562	-683	0
20	1562	-263	0
21	1073	-263	0
22	858	-53	0
23	612	-53	0
24	612	0	0
25	0	0	0

4. To edit an incorrect point value:

- a. In the History Tree, select the **CreateLine** object you want to edit.
- b. In the **Value** column of the docked *Properties* window, enter the correct x, y, and z coordinates (separated by commas).  
The value entered for **Point2** automatically applies to **Point1** for the next segment. Therefore, you need only edit **Point2** for each of the subsequent CreateLine segments.
- c. Press **Enter** to apply the new values to the model.

As you enter the values, the display of each segment updates. You may need to click  **Fit All** on the **Draw** ribbon tab to resize the object view within the *Modeler* window.

**Note:**

- If you accidentally omitted a point (for example, if one segment starts with the point-8 coordinates and ends with the point-10 coordinates):
  - a. In the History Tree, right-click the segment that precedes the invalid one and choose **Insert Segment After > Straight** from the shortcut menu.
  - b. Specify the coordinates of the missing point in the coordinate entry text boxes and press **Enter**.
- If you accidentally specified the same point twice, there will be a zero-length line segment (the start point and end point coordinates will be identical).

Right-click the zero-length line segment in the History Tree, and choose either **Delete Start Point** or **Delete End Point**.

- Finally, if you accidentally specified an extraneous point (for example, an intermediate point between point-12 and point-13):

In the History Tree, right-click the line segment that ends at the extraneous point and choose **Delete End Point**.

5. Continue with this same method to verify the values for all remaining points, correct any errors, and ensure that the appearance of the model is as expected.

## Duplicate and Mirror Polyline1

Since the waveguide combiner is symmetric about the XZ plane you can duplicate and mirror the object **Polyline1** and create the right-half of the waveguide combiner. This results in a 2D sheet object with a default name of **Polyline1\_1**.

To duplicate the object **Polyline1**:

1. Select the object **Polyline1** by either clicking it in the *Modeler* window or selecting it in the History Tree.
2. You can initiate the duplicate and mirror command using either of the following two methods:
  - Using the menu bar, click **Edit > Duplicate > Mirror**.
  - In the **Draw** ribbon tab, click  **Thru Mirror** (Mirror Duplicate).
3. Press **F3** to use the coordinate-text-box method of defining the mirror plane (rather than filling in the *DuplicateMirror* dialog box).
4. Press **Tab** to move to the **X** text box at the bottom of the program window and then enter **0 Tab 0 Tab 0** to specify the origin (X=0, Y=0, Z=0) as a point on the mirror plane.
5. Press **Enter**.

This point and the next point you specify define a line perpendicular to the mirror plane, fully locating and orienting the plane.

6. Press **Tab** to move to the **dY** text box and enter **1** to specify the normal point. (Ensure that the X and Z coordinates are both **0**.)

The normal line defined by this point lies along the Y axis.

7. Press **Enter**. The object is duplicated and mirrored, and the *Properties* dialog box appears, if configured to do so.
8. Click **OK** to dismiss the *Properties* dialog box, if it appears.

The object **Polyline1\_1**, a duplicate of object **Polyline1**, appears on the opposite side of the mirror plane you specified.

9. On the **Draw** ribbon tab, click  **Fit All**.

The model should now look like the following image:

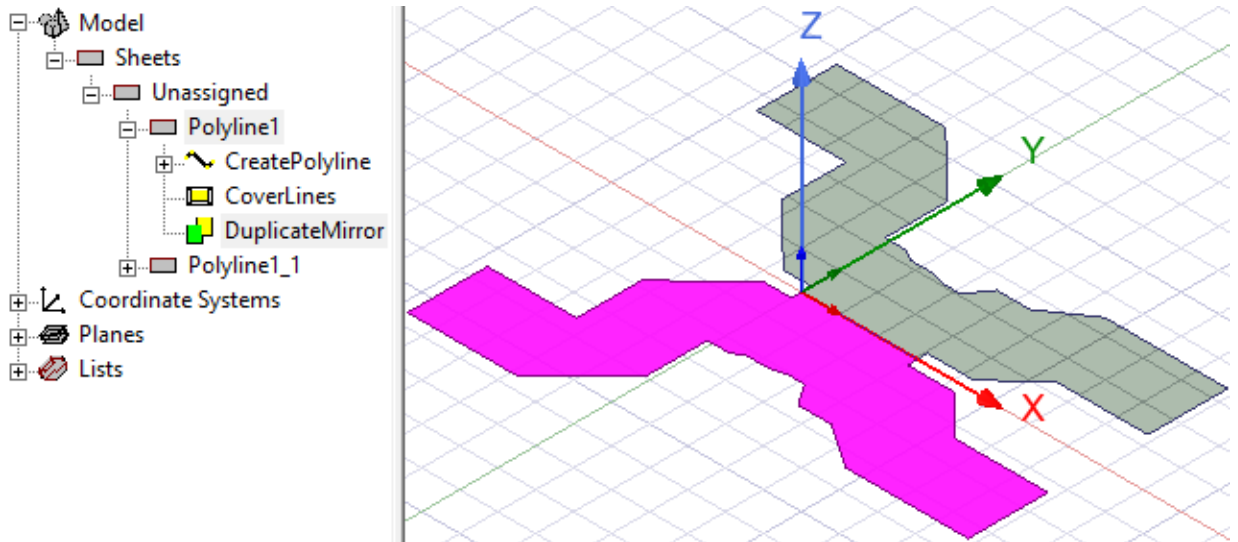

## Unite Polyline1 and Polyline1\_1

After successfully creating both halves of the waveguide combiner, unite them to make a single waveguide combiner object.

To unite both halves of the waveguide combiner:

1. Select **Polyline1**.
2. While holding down the **Ctrl** key, also select **Polyline1\_1**.

Both objects (**Polyline1** and **Polyline1\_1**) are highlighted in the History Tree, and the status bar indicates that the number of objects selected is two.

**Note:**

By default, the objects being joined to the first object selected are not preserved for later use. However, they do become part of the first object selected.

For this waveguide combiner problem, you do *not* need to preserve any objects for later use. However, if you wanted to keep a copy of the objects being joined to the first object selected, you could use one of the following methods:

- Copy the objects, perform the Boolean Unite operation, and then paste the original objects back into the design after uniting them.
- From the menu bar, click **Tools > Options > General Option**, go to **3D Modeler > Operation**, and then select the **Clone tool objects before uniting** option. This option instructs the 3D Modeler to always keep a copy of the original objects being joined. Finally, perform the Boolean Unite operation.

3. Click **Modeler > Boolean > Unite**.

The new object that is created inherits its properties (name, color, boundary, and material assignment) from the first object selected (**Polyline1**).

The resulting united object appears in the *Modeler* window, as shown below:

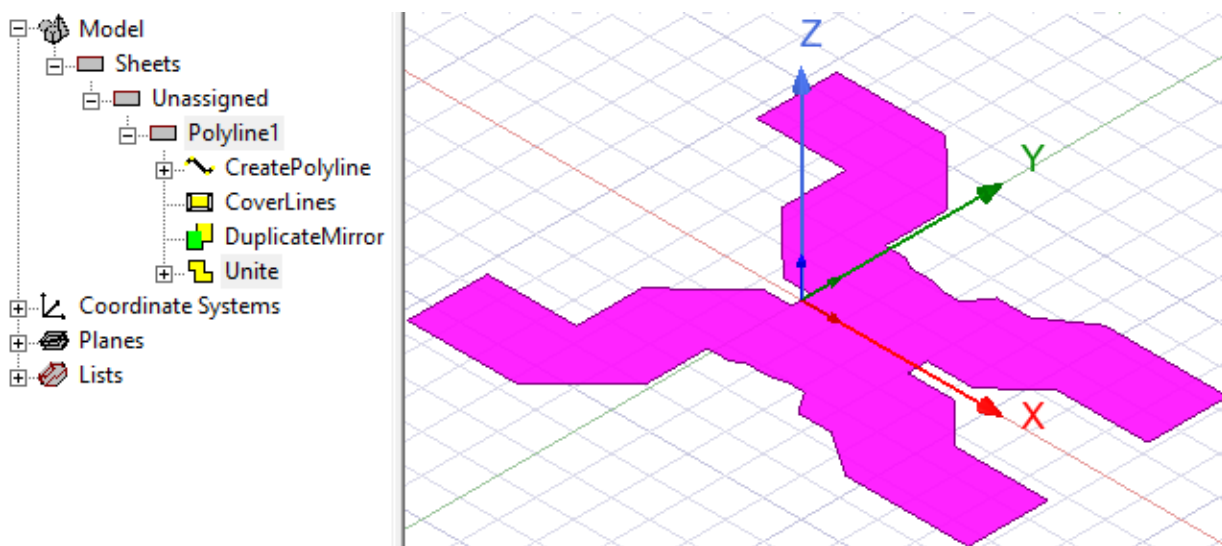

## Modify the Waveguide's Attributes

The next step in creating the 20 GHz waveguide combiner is to modify its default attributes that are displayed in the docked **Properties** window. You will rename the object, assign a color,

adjust the transparency level, and verify the material assignment. You will also verify the global lighting attributes.

## Rename Polyline1

Change the default name of the united object to specify that it is a waveguide combiner. To modify the name:

1. Reselect **Polyline1** if it is not already selected.
2. Under the **Attribute** tab of the docked *Properties* window, click **Polyline1** in the **Name** row.
3. Type **wg\_combiner** to rename the object, and press **Enter** to accept the new name.

## Assign a Color to the Waveguide

With the *wg\_combiner* object still selected and the **Attribute** tab of the *Properties* window still displayed:

4. Click the currently displayed color bar in the **Value** column of the **Color** row.

The *Color* palette appears.

5. Select the blueish-gray color (RGB settings 128, 128, 192), which is the swatch in the second row and second-last column of the *Color* palette.
6. Click **OK** to assign the color to the *wg\_combiner* object.

### Note:

While an object is selected, it retains the selection color. To see the assigned color, clear the selection by clicking a blank location in the drawing window (outside of the *wg\_combiner* object).

## Assign a Transparency to the Waveguide

To assign a transparency level to the waveguide combiner:

7. Reselect the **wg\_combiner** object, if it is not already selected.
8. Under the **Attribute** tab of the docked *Properties* window, click the default value **0** in the **Values** column of the **Transparency** row.

The *Set Transparency* window appears.

9. Move the slider to the right to increase the transparency to 0.8, or type this value into the text box.
10. Click **OK** to accept the new transparency value.

11. In the *Modeler* window, click outside the **wg\_combiner** object to clear the selection for viewing the resulting model appearance.

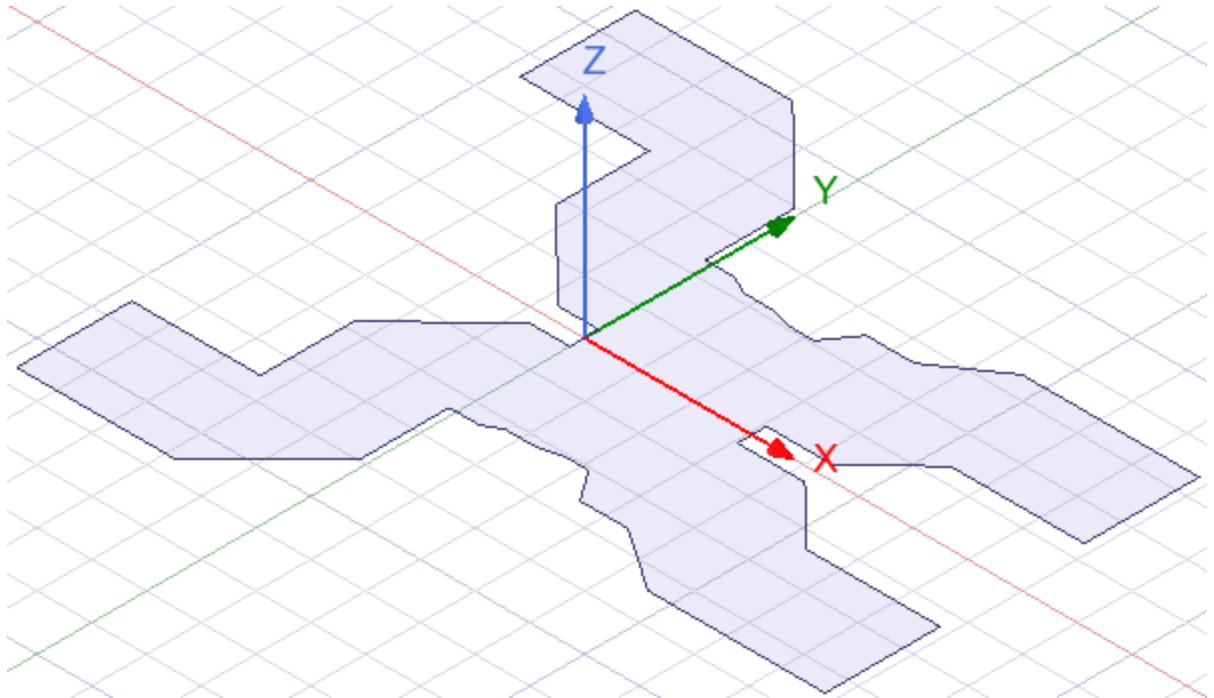

## Verify that Lighting Is Enabled and Using Default Attributes

It is not necessary to adjust the global lighting parameters for this waveguide combiner problem. However, if you want, you can change the default ambient and distant light source properties at this time.

To verify that default lighting attributes are enabled:

12. Using the menu bar, click **View > Modify Attributes > Lighting**.

The *Lighting Properties* dialog box appears.

13. Verify that the **Do not use lighting** option is cleared (to enable lighting effects).
14. Click **Reset from default** to restore default settings.

### Note:

Optionally, if you have customized lighting settings that you wish to retain, click **Save as default** to make your settings the default configuration.

15. Click **OK** to accept the settings and close the *Lighting Properties* dialog box.

## Sweep the Waveguide

Next, you must sweep the 2D object, **wg\_combiner**, along a vector to create a 3D solid object as the final waveguide combiner model.

To sweep the 2D object along a vector:

1. Select the object, **wg\_combiner**.
2. Execute the Sweep command using one of the following three methods:
  - From the menu bar, click **Draw > Sweep > Along Vector**.
  - In the **Draw** ribbon tab, click  **Sweep along vector**.
  - Right-click in the *Modeler* window and choose **Edit > Sweep > Along Vector** from the shortcut menu.
3. Specify the vector along which you want to sweep the object:
  - a. Enter **(0, 0, 0)** in the **X**, **Y**, and **Z** coordinate text boxes to specify the start point and press **Enter**.
  - b. Tab into the **dZ** text box (if the cursor is not already there), type **85** to specify the end point, and press **Enter**.

The *Sweep along vector* dialog box appears.

4. Enter **0** in the **Draft angle** text box.

This is the angle by which the profile is expanded (positive angles) or contracted (negative angles) as it is swept to produce a tapered solid object.

5. You can keep whatever the current **Draft type** setting is, since this setting will only matter when a non-zero draft angle is specified or the object is swept along a nonlinear path.

For more information, see Draft Type Options.

6. Click **OK** to complete the sweep.
7. Click **OK** to dismiss the *Properties* dialog box (if it appears).
8. Clear the selection.

Your completed 3D **wg\_combiner** object should resemble the one shown below:

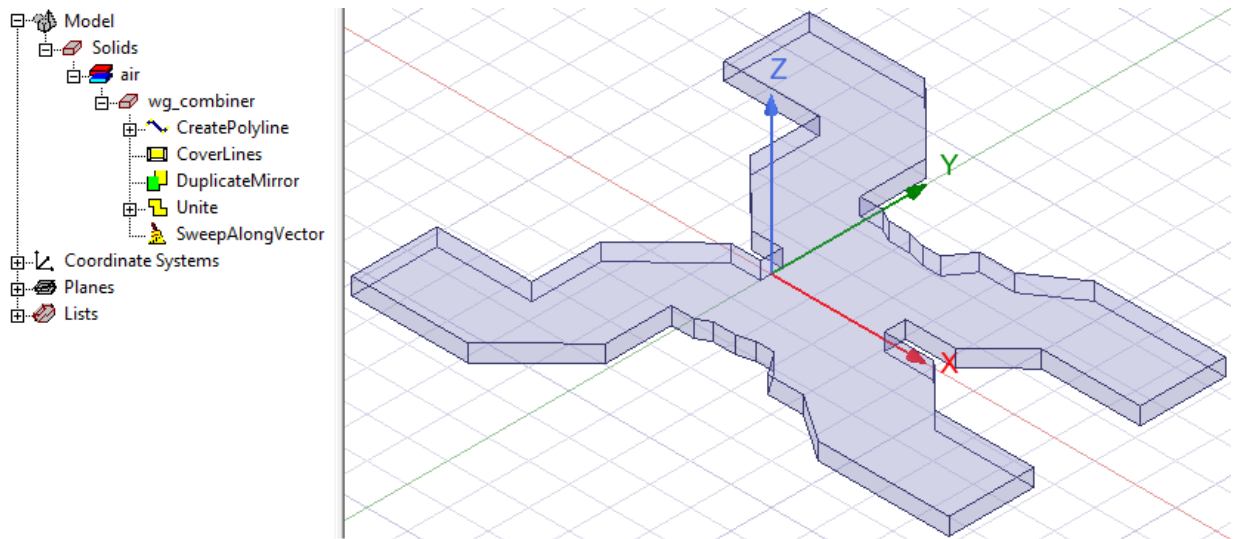

9. Click **File > Save**, or click the **Save** icon (  ), available on any ribbon tab, to save the geometry.

Now you are ready to assign all boundaries and excitations to the waveguide combiner.

# 5 - Setting Up the Problem

Now that you have created the geometry and assigned all materials for the waveguide combiner problem, you are ready to define its excitations and boundaries.

Your goals for this chapter are to:

- Define boundary conditions, in this case finite conductivity boundaries.
- Define the wave ports through which the signals enter and leave the waveguide combiner.
- Verify you correctly assigned the boundaries and excitations to the model.

## Set Up Boundaries and Excitations

Now that you have created the waveguide combiner model and defined its properties, you must define the boundary and excitation conditions. These conditions specify the excitation signals entering the structure, the behavior of electric and magnetic fields at various surfaces in the model, and any special surface characteristics.

You are ready to set up the problem.

### Time



It should take you approximately 15 minutes to work through this chapter.

## Boundary Conditions

Boundaries specify the behavior of magnetic and electric fields at various surfaces. They can also be used to identify special surfaces —such as resistors— whose characteristics differ from the default.

The following two types of boundary conditions will be used for this waveguide combiner problem:

<b>Finite Conductivity</b>	<p>This type of boundary represents an imperfect conductor. HFSS does not compute the field inside these objects; the finite conductivity boundary approximates the behavior of the field at the surfaces of the objects. Any skin-effect losses will be properly taken into account.</p> <p>For this waveguide combiner problem, a finite conductivity boundary is assigned to the bottom face and the side faces of the model (excluding the four ports).</p>
<b>Symmetry</b>	<p>In structures that have an electromagnetic plane of symmetry, such as this</p>

	<p>waveguide combiner model, the problem can be simplified by modeling only one-half of the model and identifying the exposed surface as a perfect H or perfect E boundary.</p> <p>For this waveguide combiner problem, a perfect E symmetry boundary is assigned to the top face of the model.</p>
--	---

## Assign Boundaries

First, assign all boundary conditions to the model. These assignments include two finite conductivity boundaries and one perfect E symmetry boundary. For more about the different types of boundaries available in HFSS, see [“Boundary Conditions”](#).

### Assign a Finite Conductivity Boundary to the Bottom and Side Faces

Assign a finite conductivity boundary to all the waveguide combiner’s side faces, *excluding* the four port faces.

As discussed in [“Boundary Conditions”](#), finite conductivity boundaries represent imperfect conductors. At such boundaries, the following condition holds:

$$E_{tan} = Z_s(\hat{n} * H_{tan})$$

where

- $E_{tan}$  is the component of the E-field that is tangential to the surface.
- $\hat{n}$  is the unit normal to the surface.
- $H_{tan}$  is the component of the H-field that is tangential to the surface.
- $Z_s$  is the surface impedance of the boundary,  $(1+j)/(\delta\sigma)$ , where:
  - $\delta$  is the skin depth,  $\sqrt{2/\omega\sigma\mu}$ , of the conductor being modeled.
  - $\omega$  is the angular frequency of the excitation wave.
  - $\sigma$  is the conductivity of the conductor.
  - $\mu$  is the permeability of the conductor.

The fact that the E-field has a tangential component at the surface of imperfect conductors simulates the case in which the surface is lossy.

The surfaces of any objects defined to be non-perfect conductors are automatically set to finite conductivity boundaries. HFSS does not attempt to compute the field inside these objects; the finite conductivity boundary approximates the behavior of the field at the surfaces of the objects.

The finite conductivity boundary condition is valid only if the conductor being modeled is a good conductor, and if the conductor’s thickness is much larger than the skin depth in the given frequency range.

To assign a finite conductivity boundary to the side faces of the waveguide combiner:

1. Right-click in the *Modeler* window, then choose **Selection Mode > Faces** from the shortcut menu.

In this mode you can select or deselect an object's faces instead of the entire object. When the mouse hovers over a face in the *Modeler* window, that face is outlined, which indicates that it will be selected when you click.

2. Select all the side faces of the **wg\_combiner** object except for the four port faces. Additionally, select the bottom face. Exclude the top face. Hold down the **Ctrl** key when clicking to select multiple faces.

**Note:**

- To minimize or eliminate the necessity of changing the model viewpoint, you can select a face that's behind another face. Click on the face you want to select (even though another face is in front of it). The face in the foreground is initially selected. Then, press **B** on the keyboard (or right-click and choose **Next Behind** from the shortcut menu) to select the next face behind the one just selected.
- You can also be creative with techniques for selecting multiple items in one operation. For example, click and drag to draw selection rectangles, noting that the direction you drag affects the selection behavior:
  - When dragging left-to-right, only items that are fully enclosed within the rectangle are selected.
  - When dragging right-to-left, all items that are fully enclosed within the rectangle and all items that the rectangle crosses through are selected.

The selected faces should look like the figure below. Note that the more closely spaced pair of port faces in the foreground (+X end) appear to be selected, but they are not. Due to the model viewpoint, the bottom highlighting color is seen through these two faces.

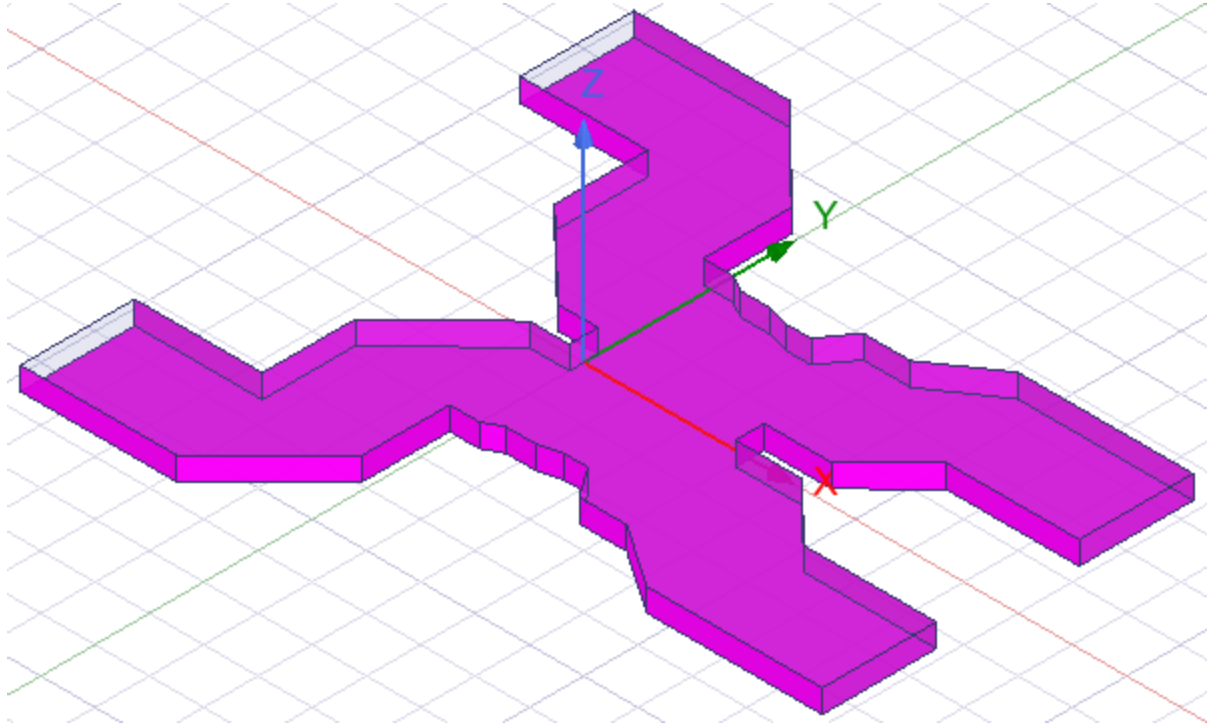

3. **Alt + double-click** near the **upper-left corner** of the Modeler canvas to switch to an alternative isometric view.

The faces in question are now in the background, and you can see that they are not selected:

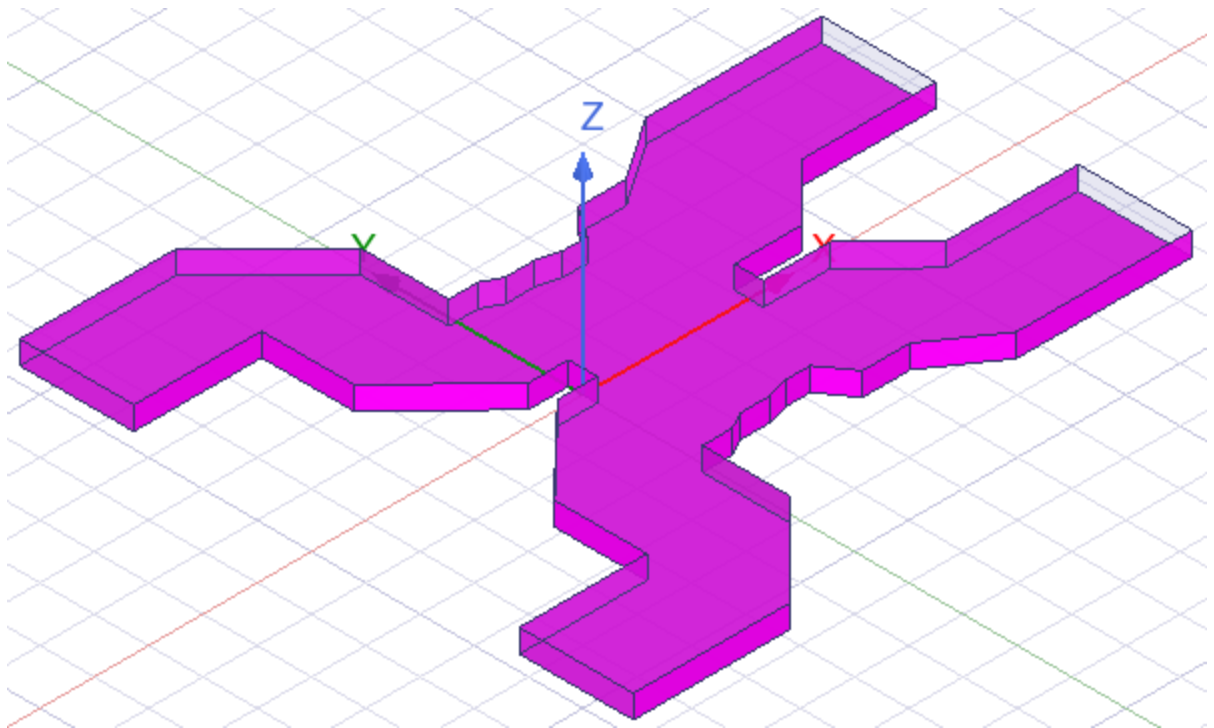

4. On the **Draw** ribbon tab, click  **Orient** to restore the default **Isometric** view.
5. On the **HFSS** menu, click **Boundaries** > **Assign** > **Finite Conductivity** or right-click in the *Modeler* window and choose **Assign Boundary** > **Finite Conductivity**.

The *Finite Conductivity Boundary* window appears. In the *Parameters* section, set the material to aluminum, as follows:

- a. Select the **Use Material** option.
- b. Click the material button (where the default *vacuum* is displayed).

The *Select Definition* dialog box appears. By default, this material browser lists all materials in the system *Materials* library, as well as the local library for the current project, which is a subset of the system library.

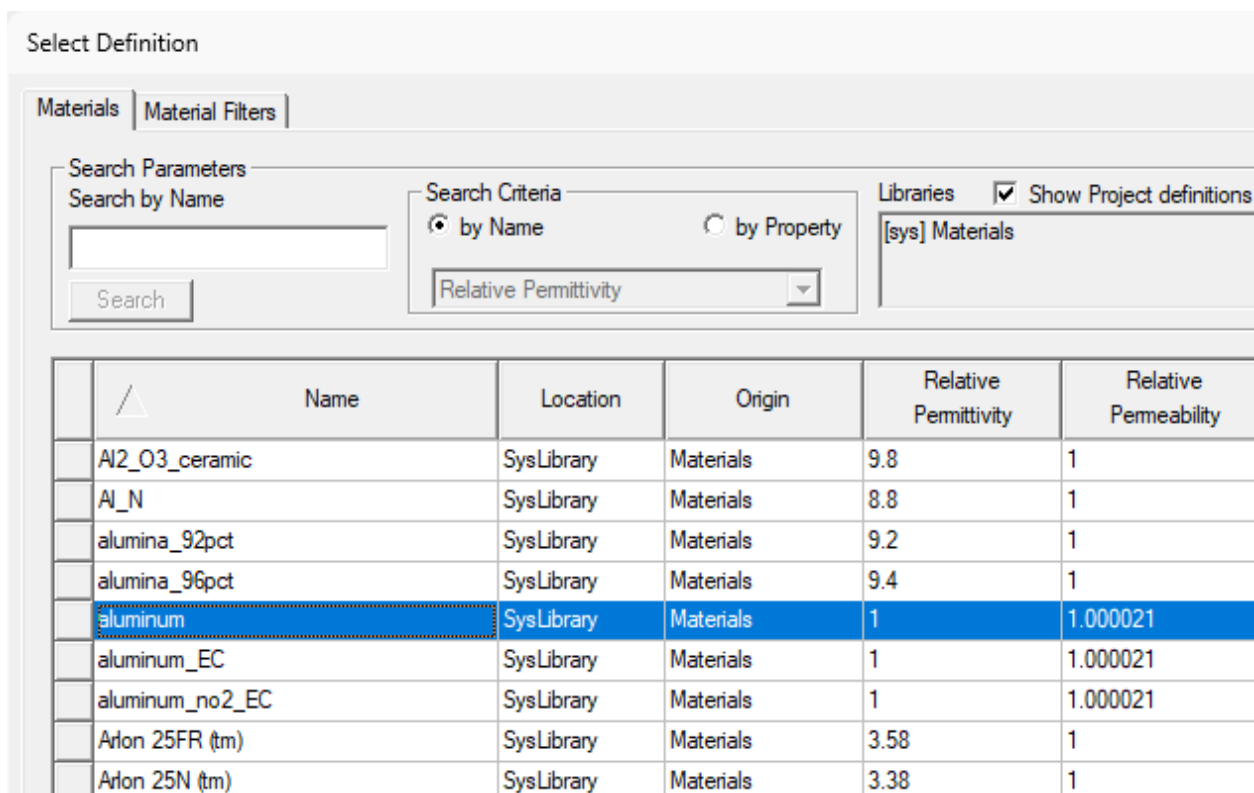

- c. Select **aluminum** from the list of materials and click **OK**.

The *Finite Conductivity Boundary* window reappears. The conductivity and per-

meability values for aluminum are now assigned to the finite conductivity boundary:

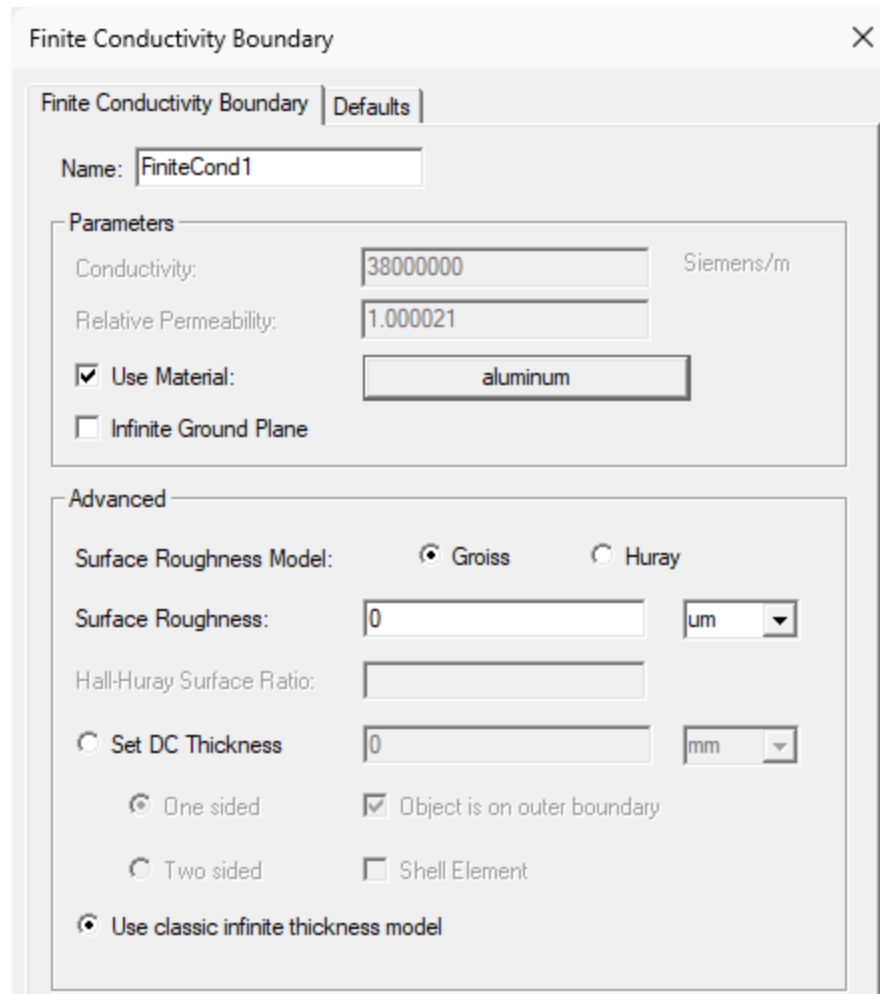

6. Clear the **Infinite Ground Plane** option if it is selected.

If selected, this option simulates the effects of an infinite ground plane, and it only affects the calculation of near- and far-field radiation during post processing. The 3D Post Processor models the boundary as a finite portion of an infinite, perfectly conducting plane.

7. Click **OK** to accept the default name **FiniteCond1** and apply the boundary.
8. The resulting finite conductivity boundary is applied to the bottom and side faces of the wg\_combiner object and appears as a subentry of *Boundaries* in the Project Manager. Select **FiniteCond1** to highlight the assigned boundary if it is not already displayed. Your model should look like the following image:

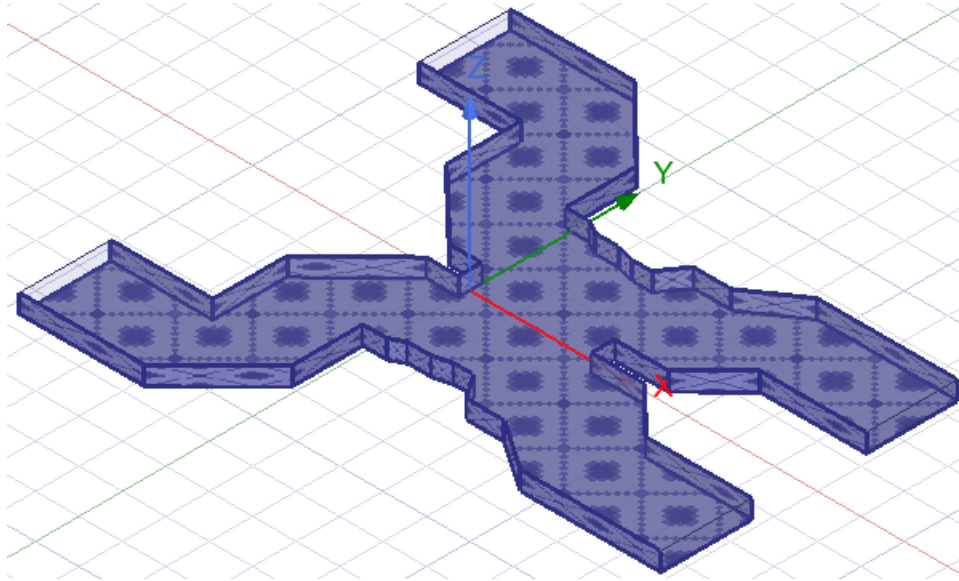

By default, the geometry, name, and vectors for the boundary appear in the *Modeler* window. For this waveguide combiner problem, it is not necessary to edit any of the boundary's default visualization settings.

**Note:**

To edit a boundary's visualization settings:

1. Click **HFSS > Boundaries > Visualization** if you want to show or hide boundaries.
2. Clear the **View Geometry**, **View Name**, or **View Vector** selection of boundaries that you want to hide from view. Select the options you want to show in the *Modeler* window.
3. Click **Close**.

## Assign a Perfect E Symmetry Boundary to the Top Face

HFSS has a boundary condition specifically for symmetry planes. Instead of defining a perfect E or perfect H boundary, you define a perfect E or perfect H symmetry plane.

When you are defining a symmetry plane, you must decide which type of symmetry boundary should be used, a perfect **E** or a perfect **H**. In general, use the following guidelines to decide which type of symmetry plane to use:

- If the symmetry is such that the E-field is normal to the symmetry plane, use a perfect **E** symmetry plane.
- If the symmetry is such that the E-field is tangential to the symmetry plane, use a perfect **H** symmetry plane.

The simple two-port rectangular waveguide shown below illustrates the differences between the two types of symmetry planes. The E-field of the dominant mode signal ( $TE_{10}$ ) is shown. The waveguide has two planes of symmetry, one vertically through the center and one horizontally.

- The horizontal plane of symmetry is a perfect **E** surface. The E-field is normal and the H-field is tangential to that surface.
- The vertical plane of symmetry is a perfect **H** surface. The E-field is tangential and H-field is normal to that surface.

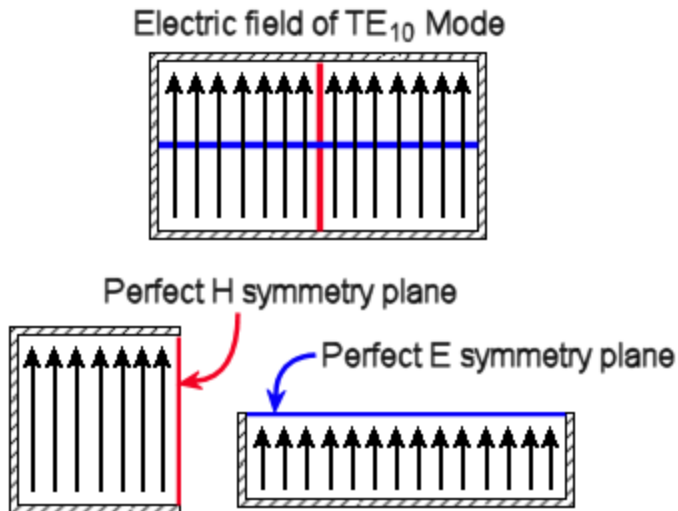

Since the top and bottom halves of the E-field are symmetrical, you can reduce the height of the waveguide combiner model to half of the actual device height. Use a perfect E symmetry boundary on the top face to get the correct results. Additionally, adjust the port impedance multiplier to obtain the correct impedance from the half-model.

Next, assign a perfect E symmetry boundary to the top face of the waveguide combiner (the symmetry plane for the model):

1. If it is still selected, deselect the finite conductivity boundary you just assigned.
2. In **Select Faces** mode, select the top face of the object **wg\_combiner**.

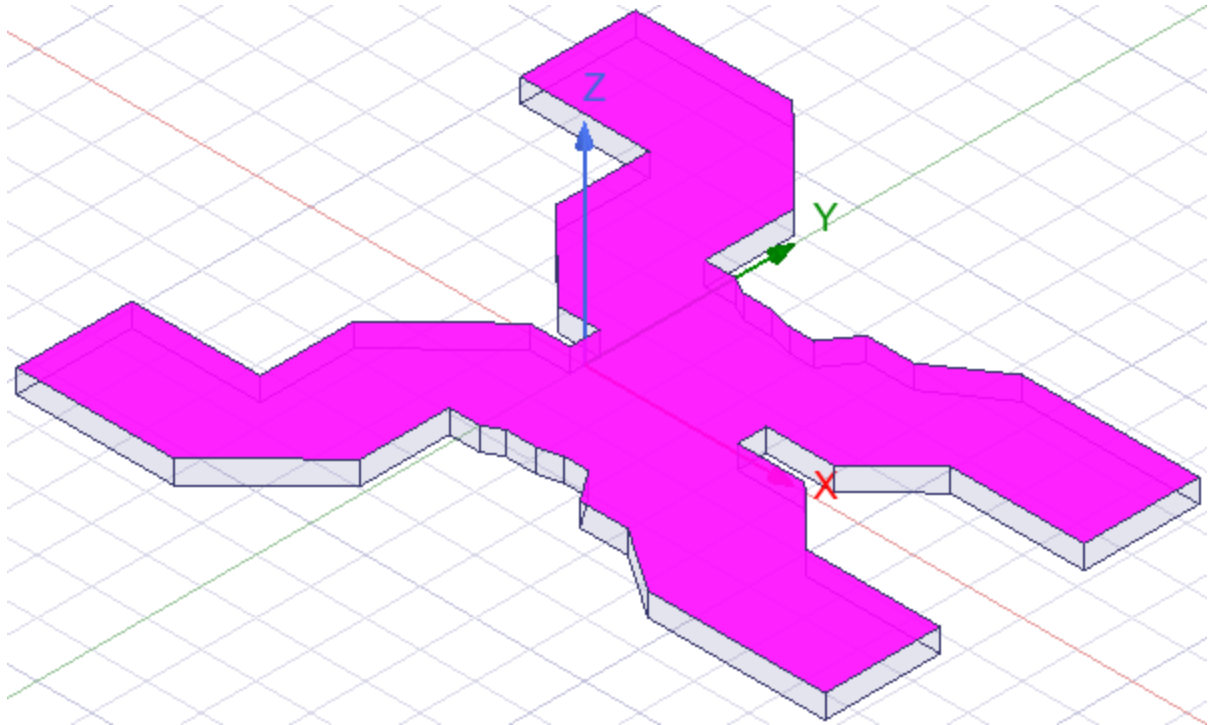

3. On the **HFSS** menu, click **Boundaries > Assign > Symmetry**.

The *Symmetry Boundary* dialog box appears.

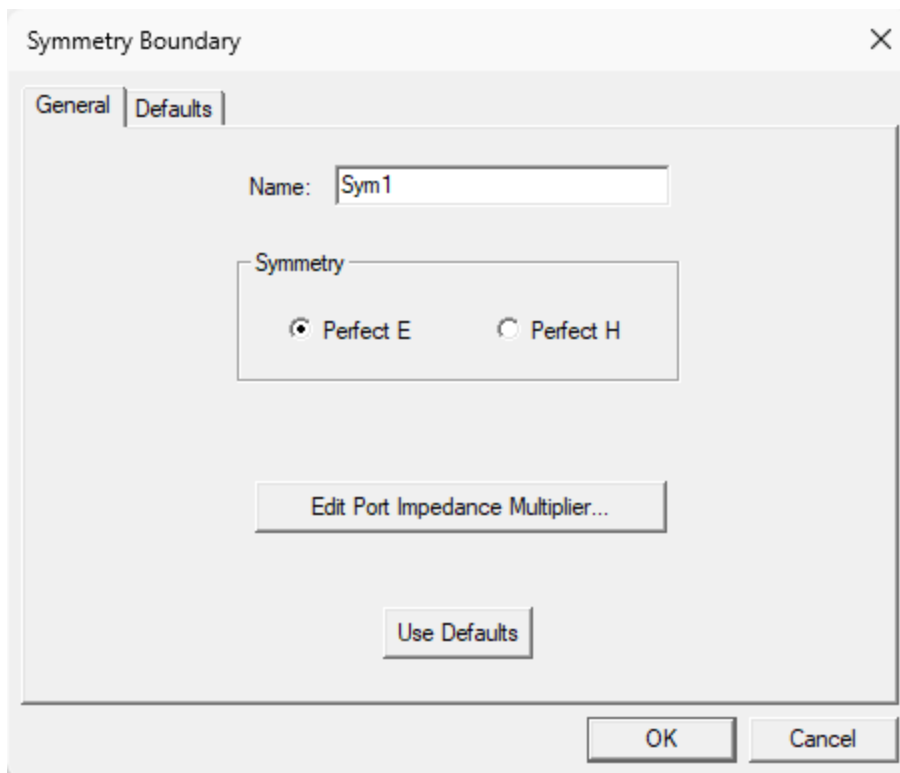

4. Select **Perfect E** as the symmetry type.
5. Because you defined a symmetry plane (allowing the model to be cut in half), the impedance computations must be adjusted by specifying an impedance multiplier.

In cases such as this waveguide combiner problem, where a perfect E plane of symmetry splits a structure in two, only one-half of the voltage differential and one-half of the power flow can be computed by the system.

Therefore, since the impedance,  $Z_{pv}$ , is given by  $Z_{pv} = \frac{V \cdot V}{P}$ , the computed value is one-half the desired value. An impedance multiplier of 2 must be specified in such cases.

Do the following to edit the impedance multiplier:

- a. Click **Edit Port Impedance Multiplier**.

The *Edit Port Impedance Multiplier* dialog box appears.

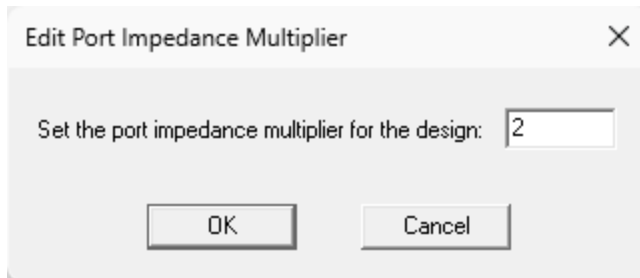

- b. Enter the value **2** in the **Impedance Multiplier** box, and then click **OK**.

**Note:**

You can also set the impedance multiplier from the **HFSS** menu by clicking **Excitations > Edit Port Impedance Multiplier**.

6. Click **OK** to accept the default name **Sym1** and apply the boundary.

The resulting perfect E symmetry boundary condition is assigned to the top face of the object **wg\_combiner**, as shown below. Select **Sym1** in the Project Manager if the boundary is not already displayed.:

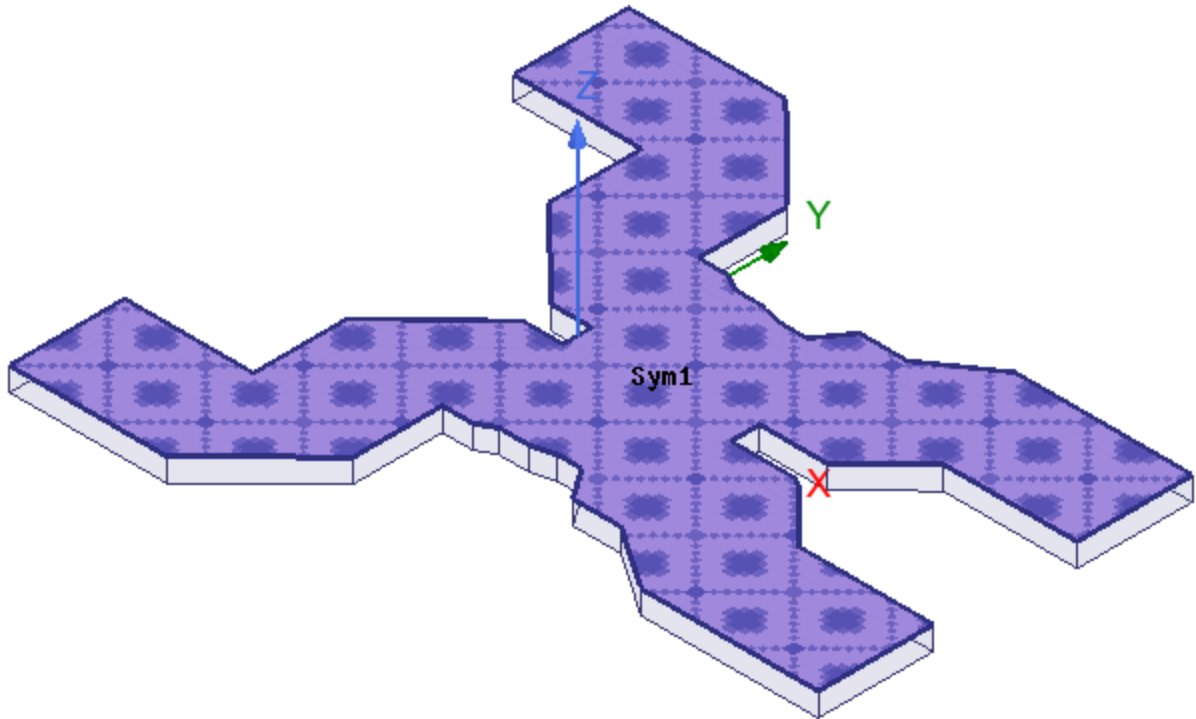

## Excitation Conditions

Wave ports define surfaces exposed to non-existent materials (generally the background or materials defined to be perfect conductors) through which excitation signals enter and leave the structure.

Wave ports represent places in the geometry through which excitation signals enter and leave the structure. They are used when modeling strip lines and other waveguide structures, such as this waveguide combiner problem. Wave ports are typically placed on the perfect E interface between the 3D object and the background to provide a window that couples the model device to the external world.

For this waveguide combiner problem, a wave port is assigned to each end-face of the model's four waveguide sections.

## Assign Excitations

Now you will assign all excitations to the waveguide combiner model. These excitations include wave ports assigned to each end face of the model's four waveguide sections, as shown below. The model orientation in this image is Trimetric, and the port faces have been selected for clarity:

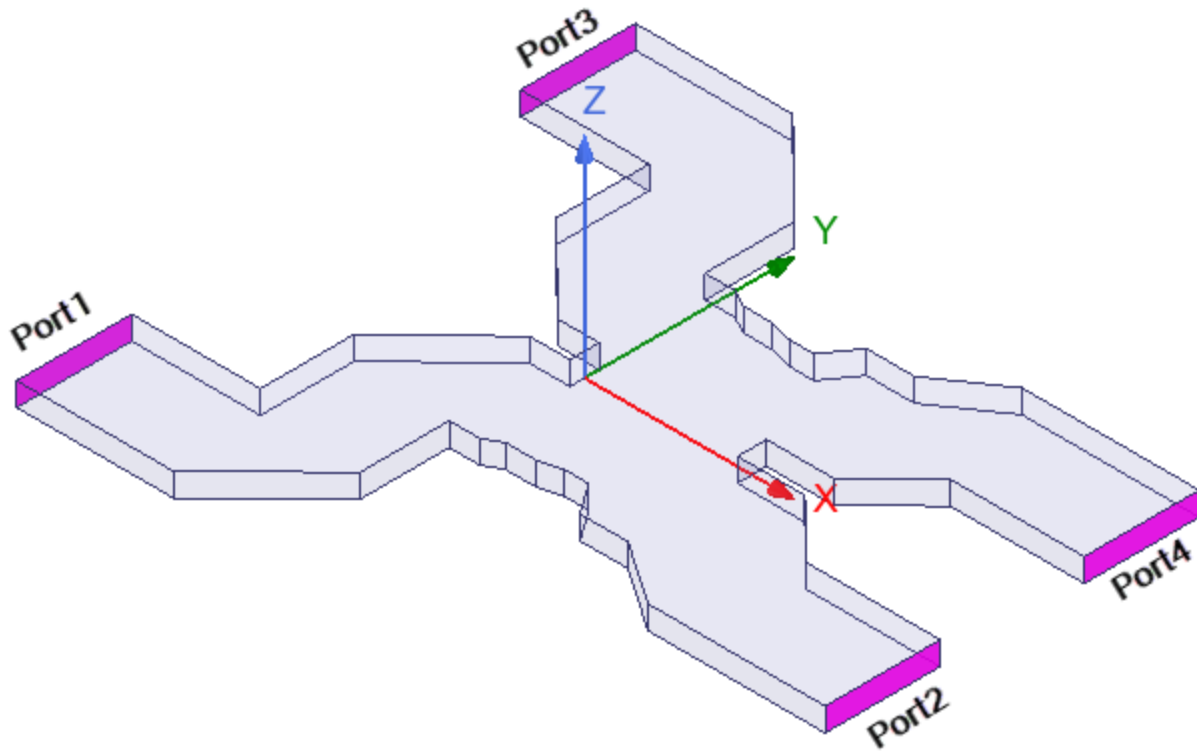

Wave ports represent places in the geometry through which excitation signals enter and leave the structure. HFSS assumes that each wave port you define is connected to a semi-infinitely long waveguide that has the same cross-section and material properties as the port.

When solving for the S-parameters, HFSS assumes that the structure is excited by the natural field patterns (modes) associated with these cross-sections. The 2D field solutions generated for each wave port serve as boundary conditions at those ports for the 3D problem. The final field solution computed must match the 2D field pattern at each port.

For this waveguide combiner model, you will assign four wave ports to the locations shown in the above image. For face-selection convenience, you will assign them in a nonsequential order.

The functions of each wave port in this waveguide combiner model are as follows:

**Port1** One of two output ports, along with Port3.

In a later procedure, each of the opposite two ports (2 and 4) will receive the output from a solid-state power amplifier (SSPA). The output at Port1 depends on the phase angle between the inputs applied to ports 2 and 4. With the Port4 input 90-degrees out-of-phase with Port2, we expect all of the power to flow out of Port1, fully combining the SSPA outputs.

- Port2** One of two input ports, along with Port4, to which the output of an SSPA will be fed.
- Port3** One of two output ports, along with Port1.  
The output at Port3 depends on the phase angle between the inputs applied to ports 2 and 4. With the Port4 input 90-degrees out-of-phase with Port2, we expect Port3 to be isolated with essentially zero output.
- Port4** One of two input ports, along with Port2, to which the output of an SSPA will be fed.  
Port4 will receive the output of the SSPA but 90-degree out-of-phase relative to Port2.

## Assign Wave Port 1

You will first the model viewpoint for convenient visualization and selection of the faces for wave port 1 and wave port 3.

To assign wave port 1:

1. Deselect the Perfect E boundary you just assigned, if it is still selected.
2. On the **Draw** ribbon tab, click  **Orient** to ensure that you are starting from the default **Isometric** view.

You need not access the *Orient* drop-down menu because *Isometric* is the default choice.

3. While holding down the **Z** key, click and drag using the **middle** mouse button (**Z + MMB + drag**) as follows:

Drag the cursor in a half-circle path (180° arc) about the center of the Modeler canvas from 12 o'clock to 6 o'clock (either clockwise or counterclockwise). Then release the mouse button and key.

This action rotates the model viewpoint 180° about the Z axis. The faces for assigning ports 1 and 3 should now be facing towards you with the model in an alternative isometric viewpoint.

4. In **Select Faces** mode, select the face of Port1 (see the image below step 7).
5. On the **HFSS** menu, click **Excitations > Assign > Port > Wave Port** or right-click in the Modeler window and choose **Assign Excitation > Port > Wave Port**.

The *Wave Port* wizard appears.

6. In the *Wave Port: General* dialog box, enter the name **Port1**, keep the default Mode settings, and click **Next**.

7. In the *Wave Port: Post Processing* dialog box, accept the default settings and click **Finish** to complete the wave port assignment.

**Port1** is assigned to the waveguide and now appears as a subentry of *Excitations* in the Project Manager. Select the **Port1** entry if its visualization is not already displayed on the model.

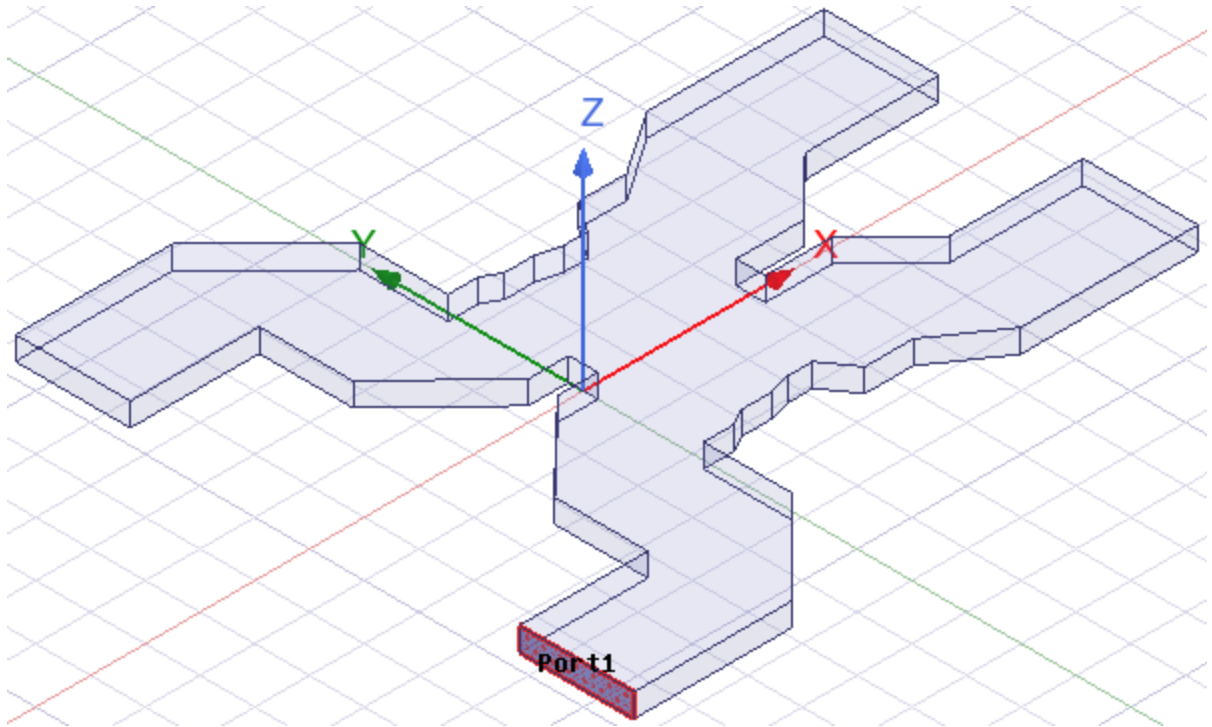

### Assign Wave Port 3

To assign wave port 3, use the same model viewpoint and the same assignment procedure you followed when you assigned wave port 1:

1. Clear the **Port1** selection.
2. In **Select Faces** mode, select the face of Port3:

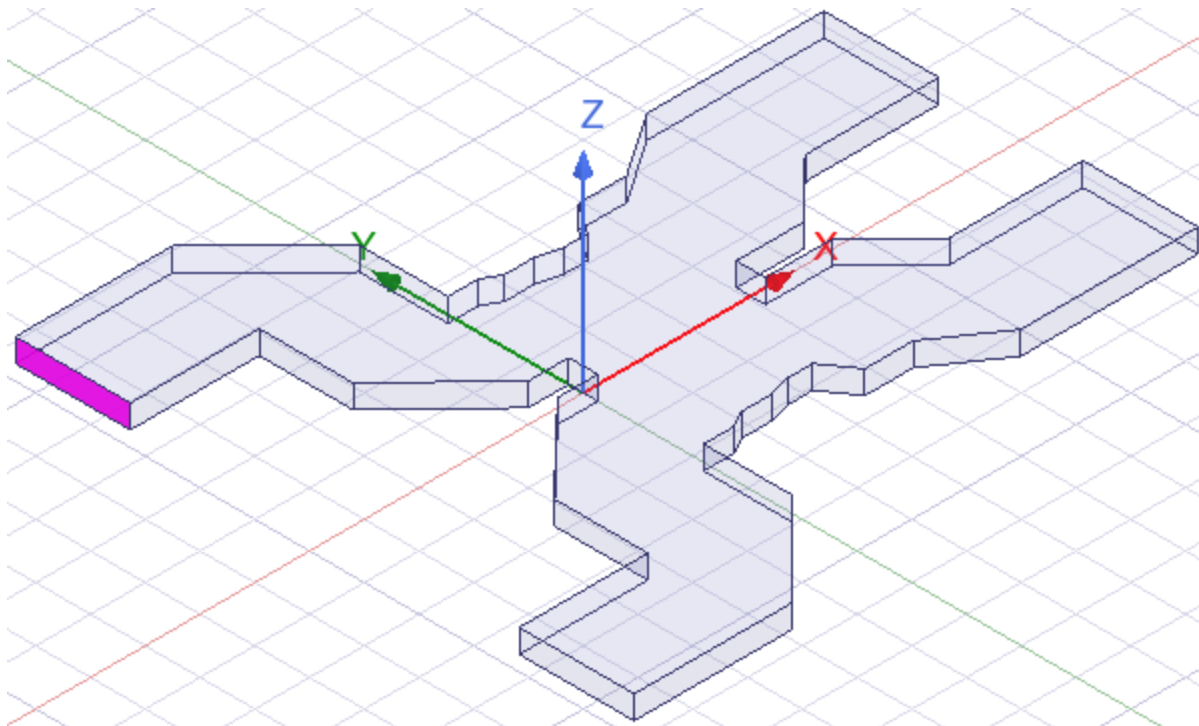

3. On the **HFSS** menu, click **Excitations > Assign > Port > Wave Port**.

The *Wave Port* wizard appears.

4. In the *Wave Port: General* dialog box, enter the name **Port3**, keep the default Mode settings, and click **Next**.
5. In the *Wave Port: Post Processing* dialog box, accept the default settings and click **Finish** to complete the wave port assignment.

**Port3** is assigned to the waveguide and now appears as a subentry of *Excitations* in the Project Manager.

## Assign Wave Port 2

To assign wave port 2, you will reorient the view and then use the same procedure you followed to assign wave ports 1 and 3, but with the addition of an integration line.

When HFSS computes the excitation field pattern at a port, the direction of the field at  $\omega t = 0$  is arbitrary; the field can always point in one of at least two directions.

For both wave port 2 and wave port 4, you must calibrate the port relative to some reference orientation by defining an integration line in the *up* (that is, +Z) direction.

To assign wave port 2:

1. Clear any current selection.
2. On the **Draw** ribbon tab, click  **Orient** to restore the default **Isometric** view.
3. In **Select Faces** mode, select the face of Port2.

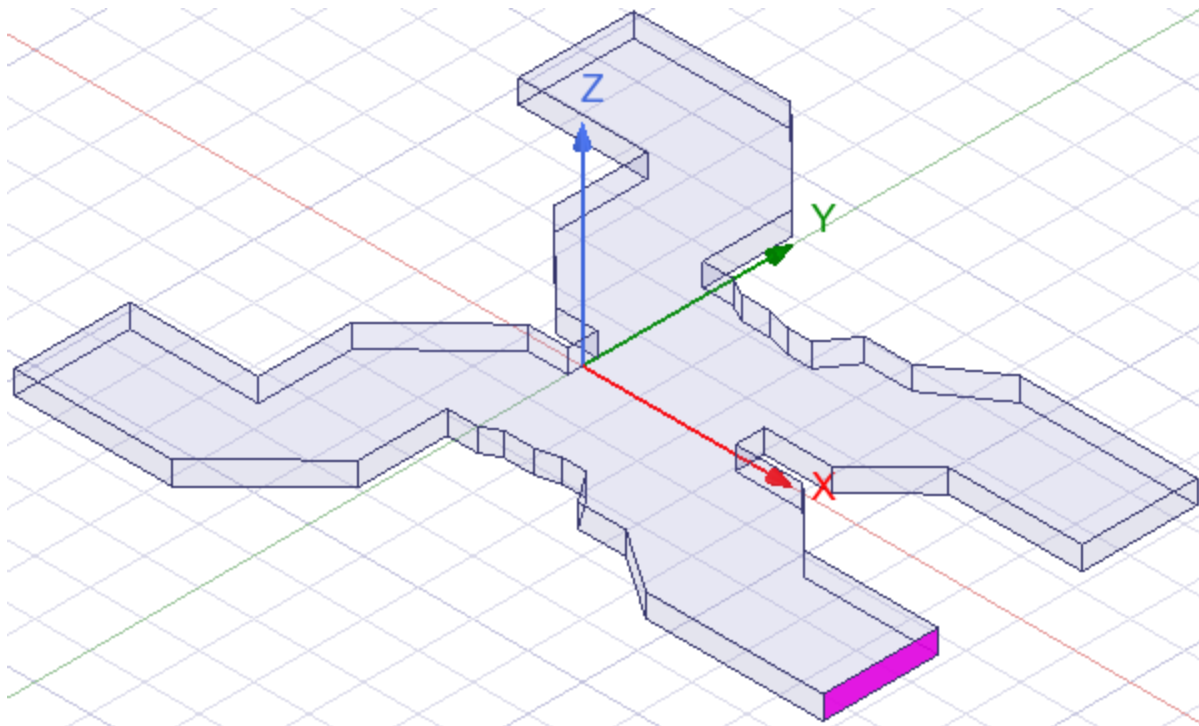

4. On the **Draw** ribbon tab, click  **Fit Selected** to zoom into the selected port face.
5. On the **HFSS** menu, click **Excitations** > **Assign** > **Port** > **Wave Port**.

The *Wave Port* wizard appears.

6. In the *Wave Port: General* dialog box, enter the name **Port2**.
7. Click in row 1 of the **Integration Line** column and choose **New Line** from the drop-down menu.

The *Wave Port* wizard disappears while you draw the vector.

8. Define the integration line:
  - a. Select the start point by clicking the center of the bottom edge of the face. Your cursor will appear as a triangle when it is at this exact location, and it will snap to this midpoint when clicked.
  - b. Select the end point by clicking the center of the top line on the face, which is directly vertical to the start point you just selected. Again, your cursor will appear as a triangle when it is at this exact location.

The endpoint defines the direction and length of the integration line.

The *Wave Port* wizard reappears, still at the *Wave Port: General* step.

9. Click **Next**.

10. In the *Wave Port: Post Processing* dialog box, accept the default settings and click **Finish** to complete the wave port assignment.

**Port2** is assigned to the waveguide and now appears as a subentry of *Excitations* in the Project Manager. This wave port, with its integration line, is shown below:

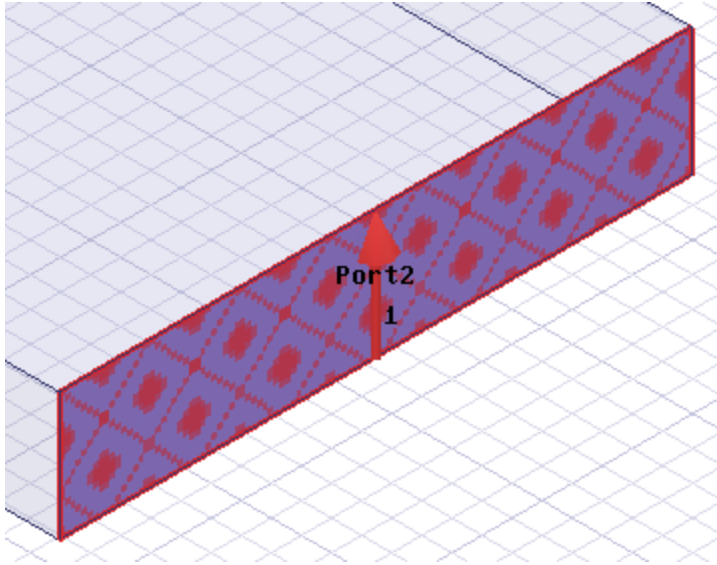

### Assign Wave Port 4

To assign wave port 4, you will use the same procedure you followed when you assigned wave port 2:

1. Clear any current selection.
2. On the **Draw** ribbon tab, click  **Fit All** to zoom out and see the full model.
3. In **Select Faces** mode, select the face of Port4.

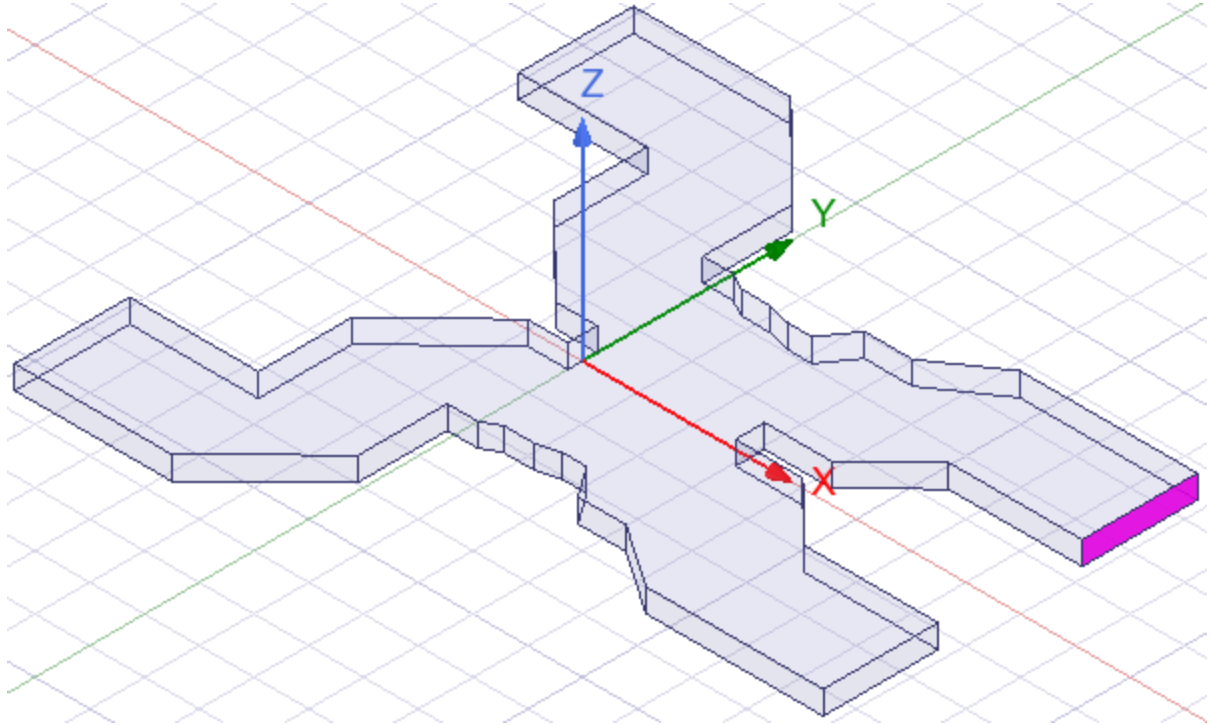

4. On the **Draw** ribbon tab, click  **Fit Selected** to zoom into the selected port face.
5. On the **HFSS** menu, click **Excitations** > **Assign** > **Port** > **Wave Port**.

The *Wave Port* wizard appears.

6. In the *Wave Port: General* dialog box, enter the name **Port4**.
7. Click in the first row of the **Integration Line** column and select **New Line** from the drop-down menu.

The *Wave Port* wizard disappears while you draw the vector.

8. Define the integration line:
  - a. Select the start point by clicking the center of the bottom line on the face. Your cursor will appear as a triangle when it is at this exact location, and it will snap to this midpoint when clicked.
  - b. Select the end point by clicking the center of the top line on the face, which is directly vertical to the start point you just selected. Again, your cursor will appear as a triangle when it is at this exact location.

The endpoint defines the direction and length of the integration line.

The *Wave Port* wizard reappears at the *Wave Port: General* step.

9. Click **Next**.

10. In the *Wave Port: Post Processing* dialog box, accept the default settings and click **Finish** to complete the wave port assignment for port 4.

*Port4*, with its integration line, is assigned to the waveguide combiner and appears as a subentry of *Excitations* in the Project Manager.

**Note:**

To edit a wave port assignment:

1. In the *Project Manager* window, double-click the name of the wave port assignment listed in the tree.  
The *Wave Port* dialog box appears.
2. Click the appropriate tabs (General, Post Processing, Defaults) to edit any port assignment information.
3. Click **OK** to apply the assignment revisions.

11. On the **Draw** ribbon tab, click  **Fit All** to zoom out and see the full model again.

## Verify All Boundary and Excitation Assignments

Now that you have assigned all the necessary boundaries and excitations to a model, you should review their specific locations on the model in the solver view.

When you verify boundaries and excitations in the solver view, you review the locations of the boundaries and excitations as you have defined them for generating a solution (solving).

HFSS runs an initial mesh and determines the locations of the boundaries and excitations on the model.

Then, you can select a boundary or excitation from the list in the **Boundary Display (Solver View)** window to view its highlighted area in the model.

To check the solver's view of boundaries and excitations:

1. Clear any current selection.
2. Click **HFSS > Boundary Display (Solver View)** or right-click the **Waveguide Combiner (Modal Network)** entry in the Project Manager and choose **Boundary Display (Solver View)** from the shortcut menu.

HFSS runs an initial mesh and determines the locations of the boundaries and excitations on the model.

The **Solver View of Boundaries** window appears, listing all the boundaries and excitations for the active model in the order in which they were assigned.

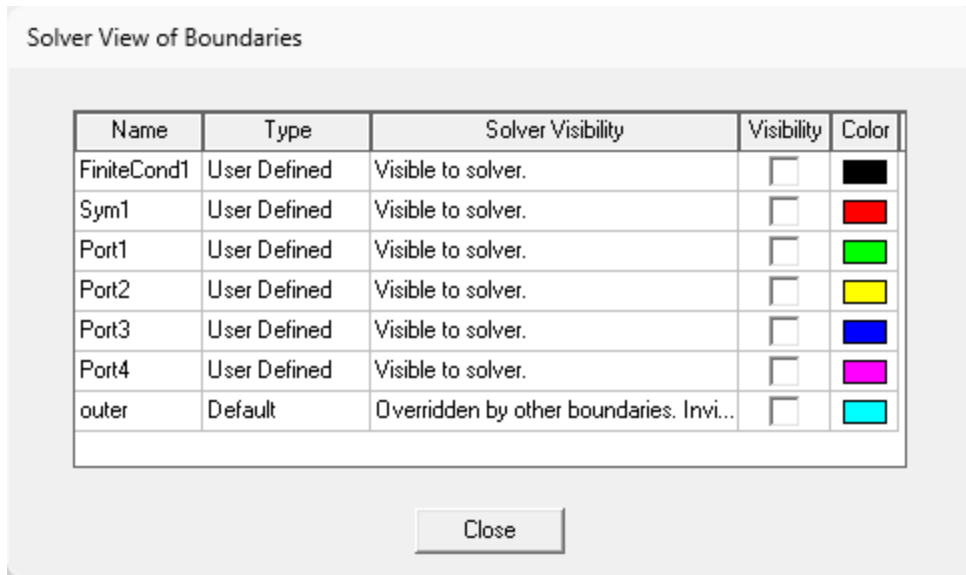

3. Select a check box in the **Visibility** column that corresponds with the boundary or excitation for which you want to review its location on the model.

The selected boundary or excitation appears in the model in the color it has been assigned, as indicated in the **Color** column.

- **Visible to Solver** appears in the **Solver Visibility** column for each boundary that is valid.
  - **Overridden** appears in the **Solver Visibility** column for each boundary or excitation that overwrites any existing boundary or excitation with which it overlaps.
4. Verify that the boundaries or excitations you assigned to the model are being displayed as you intended for solving purposes.
  5. If required, modify the parameters for those boundaries or excitations that are incorrect.
  6. Click **Close** and then, from the **File** menu, click **Save**. Or, in any tab of the ribbon, click



**Save.**

#### Warning:

Be sure to save your models frequently. While Ansys Electronics Desktop does periodically autosave models, the most convenient way to prevent loss of work in the event of a problem is to save frequently.

You are now ready to set up the solution parameters for this waveguide combiner problem and generate a solution.

## 6 - Set up and Generate a Solution

Now that you have defined and verified all the boundaries and excitations for the waveguide combiner problem, you are ready to set up and generate a solution.

Your goals for this chapter are to:

- Set up the solution parameters that will be used in calculating the solution.
- Validate the project setup.
- Generate the solution.
- View the solution data, such as convergence and matrix data information.

**Time** Aside from the solution time, it should take about 15 minutes for you to complete the setup steps and to review the solution data.



Depending on your computing resources, the solution time may vary considerably. This problem solved in approximately 10 minutes on a 1.4 GHz PC with 1 gigabyte of RAM. On a 12-core, 3 GHz, Xeon-processor-based PC with 64 GB of RAM, the solution took approximately 50 seconds to complete.

### Specify Solution Options

Before you can generate a solution, you need to specify the solution parameters. This controls how HFSS computes the requested solution.

Each solution setup includes the following information:

- General data about the solution's generation.
- Adaptive mesh refinement parameters, if you want the mesh to be refined iteratively in areas of highest error.
- Frequency sweep parameters, if you want to solve over a range of frequencies.

You can define more than one solution setup per design. However, you will define only *one* solution setup for this waveguide combiner problem.

### Add a Solution Setup

Now, you will specify how HFSS will compute the solution by adding a solution setup to the waveguide combiner design.

To add a solution setup to the design:

1. Use one of the following three methods to add a solution setup to the design:
  - From the **HFSS** menu, click **Analysis Setup > Add Solution Setup > Advanced**.
  - From the **Simulation** ribbon tab, click  **Setup > Advanced**.
  - From the Project Manager, right-click **Analysis** and choose **Add Solution Setup > Advanced**.

The *Driven Solution Setup* dialog box appears.

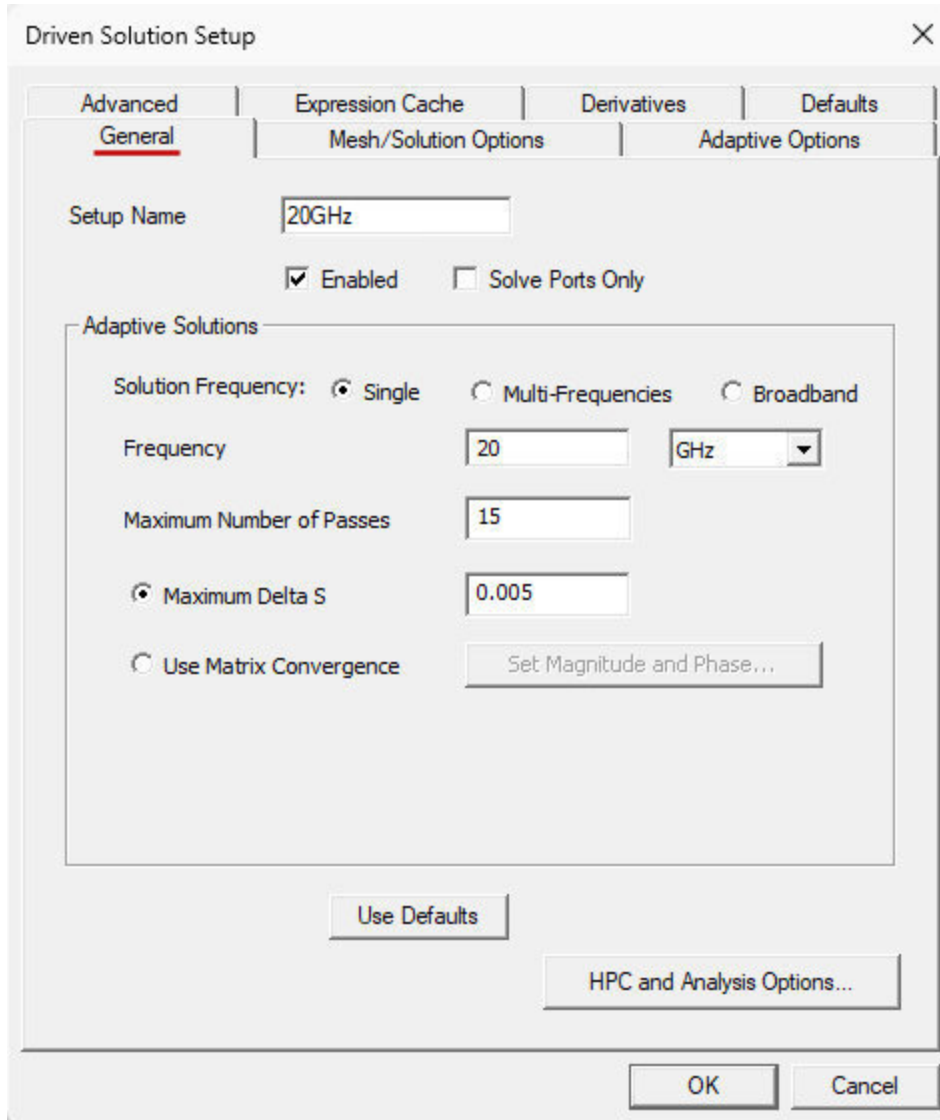

For advanced solution setups, the *Driven Solution Setup* dialog box is divided into the following tabs:

<b>General</b>	Includes general solution settings such as the setup name, adaptive solution frequency, number of passes, and convergence cri-
----------------	--

	teria.
<b>Mesh/Solution Options</b>	Includes mesh refinement options, choice of basis function order, solver selection, and other solver options.
<b>Adaptive Options</b>	Includes options to control the adaptive solution process (such as maximum refinement percentage per pass, and minimum number of converged passes).
<b>Advanced</b>	Includes advanced settings for optionally importing a mesh, port options, and save fields options.
<b>Expression Cache</b>	For building a list of expressions (including post processing variables) that you can use for convergence of adaptive analyses.
<b>Derivatives</b>	If your design contains variables, they are listed here. HFSS can calculate derivatives for your variables.
<b>Defaults</b>	Enables you to save the current settings as the defaults for future solution setups or revert the current settings to HFSS's standard settings.

2. Under the **General** tab:
  - a. Specify the following values:

<b>Setup Name</b>	<b>20GHz</b> You can override the default setup name with something more meaningful, if desired. In this case, we will identify it using the adaptive solution frequency.
<b>Solution Frequency</b>	<b>20 GHz</b> For every modal driven solution setup, you must specify the frequency at which to generate the solution. For this waveguide combiner model, you will solve over a range of frequencies, which will require you to define a frequency sweep in <a href="#">"Add a Discrete Fre-</a>

	<p><a href="#">quency Sweep</a>". If a frequency sweep is solved, an adaptive analysis is performed only at the solution frequency.</p>
<p><b>Maximum Number of Passes</b></p>	<p><b>15</b></p> <p>The <b>Maximum Number of Passes</b> value is the maximum number of mesh refinement cycles that you would like HFSS to perform. This value is a stopping criterion for the adaptive solution; if the maximum number of passes has been completed, the adaptive analysis stops. If the maximum number of passes has not been completed, the adaptive analysis will continue unless the convergence criteria are reached.</p>
<p><b>Maximum Delta S per Pass</b></p>	<p><b>0.005</b></p> <p>The delta S is the change in the magnitude of the S-parameters between two consecutive passes. The value you set for <b>Maximum Delta S Per Pass</b> is a stopping criterion for the adaptive solution. If the magnitude and phase of all S-parameters change by an amount less than this value from one iteration to the next, the adaptive analysis stops. Otherwise, it continues until the requested number of passes is completed.</p>

- b. Accept all remaining default settings.
3. Accept all default settings on the **Options**, **Advanced**, and **Default** tabs.
4. Click **OK**.

The *Edit Frequency Sweep* dialog box appears. Keep this dialog box open. In the next topic, you will define a discrete frequency sweep.

## Add a Frequency Sweep

For models that include any type of assigned port excitation, upon completing the addition of an advanced solution setup (previous topic), the *Edit Frequency Sweep* dialog box appears automatically. Define a sweep to specify a range of frequencies over which results can be plotted, such as S Parameters. HFSS performs the sweep after the adaptive solution.

For this waveguide combiner model, you will add an *Interpolating* frequency sweep to the solution setup. An Interpolating sweep estimates a solution for an entire frequency range. HFSS chooses the frequency points at which to solve the field solution so that the entire interpolated solution lies within a specified error tolerance. You will specify a range of 19.5 GHz to 20.4 GHz, with a Step Size of 0.01 GHz. The results will include 91 frequency points. By default, the field solution is only saved for the final frequency point, and we will not choose to save additional fields for this simulation.

Be aware that HFSS uses the finite element mesh refined during an adaptive solution at the specified solution frequency. It uses this mesh without further refinement. Because the mesh for the adaptive solution is optimized only for the specified solution frequency, it is possible that the accuracy of the results could vary at frequencies significantly far away from the adaptive solution frequency. If you wish to minimize the variance, you can opt to use the center of the frequency range as the solution frequency. Then, after inspecting the results, run additional adaptive passes with the solution frequency set to the critical frequencies.

Add an interpolating frequency sweep to the solution setup:

1. The *Add Frequency Sweep* dialog box should already be displayed as a result of adding a solution setup to a model with port excitations assigned.

### Note:

To manually access the *Edit Frequency Sweep* dialog box (for example to add a second sweep or if you inadvertently closed the dialog box prematurely), do the following:

- a. Select **Setup1** under Analysis in the Project Manager.
- b. Begin adding a frequency sweep using one of the following three methods:
  - From the **Simulation** ribbon tab, click  **Sweep**.
  - From the **HFSS** menu, click **Analysis Setup > Add Frequency Sweep**.
  - Under *Analysis > Setup1* in the Project Manager, right-click **Setup1** and choose **Add Frequency Sweep** from the shortcut menu.

The *Edit Frequency Sweep* dialog box appears.

2. For the **Sweep Name**, specify **19p5\_25p4GHz**, indicating the sweep range. (We are using the character "p" because decimal points are not permitted within names.)
3. From the **Sweep Type** drop-down menu, select **Interpolating**.
4. In the **Frequency Sweeps** table, select or enter these values to define the sweep:

Type	Linear Step
Start	19.5GHz
Stop	20.4GHz
Step Size	0.01GHz

The table title should indicate *[10 points defined]* after Frequency Sweeps.

5. Clear **Save Fields (All Frequencies)**, if it's currently selected.

When selected, the **Save Fields** option saves the field solution for each specified point. The more steps you request, the longer it takes to complete the frequency sweep. However, the S-parameters are always saved for every frequency point.

The dialog box should look like the following image:

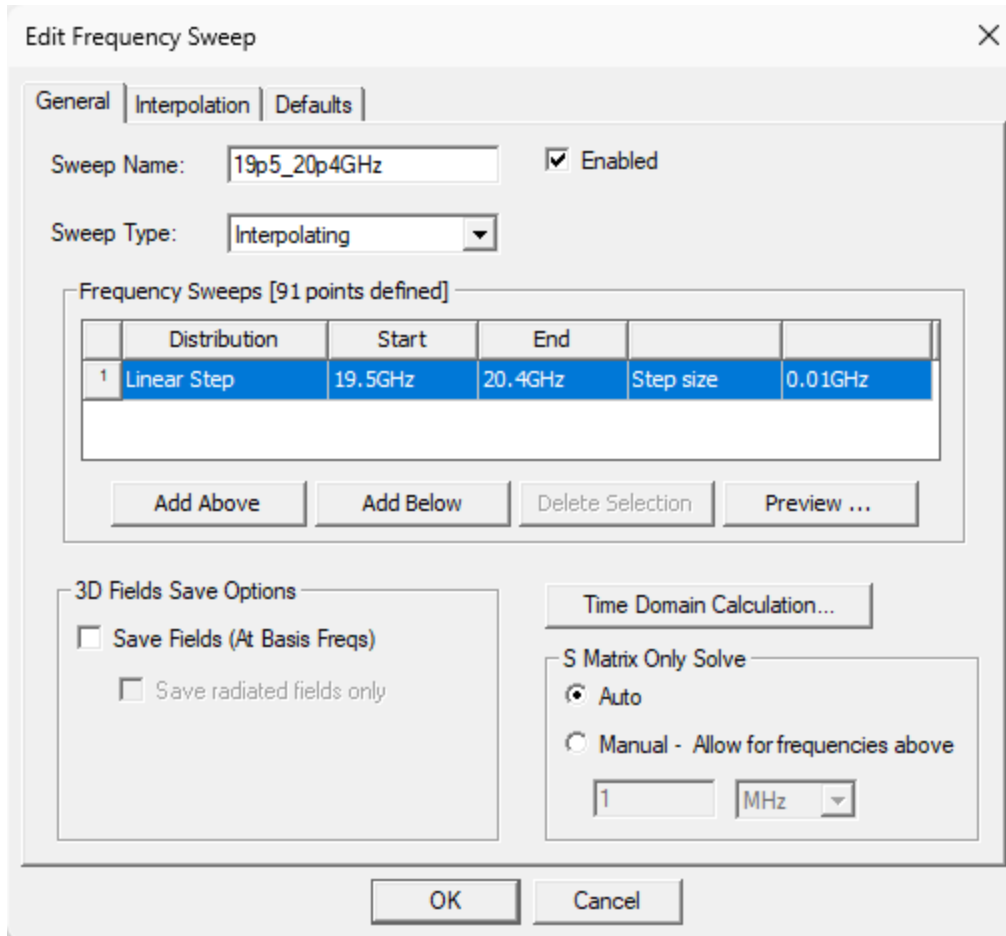

6. Click **Preview** to view each of the 91 frequency values for the specified 0.01 GHz step size increment within the frequency range you specified.
7. Click **OK**.

**19p5\_20p4** now appears as a subentry under *Analysis > 20GHz* in the Project Manager.

## Validate the Project Setup

Before you run an analysis on the waveguide combiner model, it is important to first perform a validation check on the project. HFSS runs a check on all the setup details of the active project to verify that all the necessary steps have been completed and their parameters are reasonable.

To perform a validation check on the project **WaveguideCombiner**:

1. From the menu bar, click **HFSS > Validation Check** or, from the **Simulation** ribbon tab, click  **Validate**.

HFSS checks the project setup, and then the *Validation Check* window appears.

2. View the results shown in the *Validation Check* window.

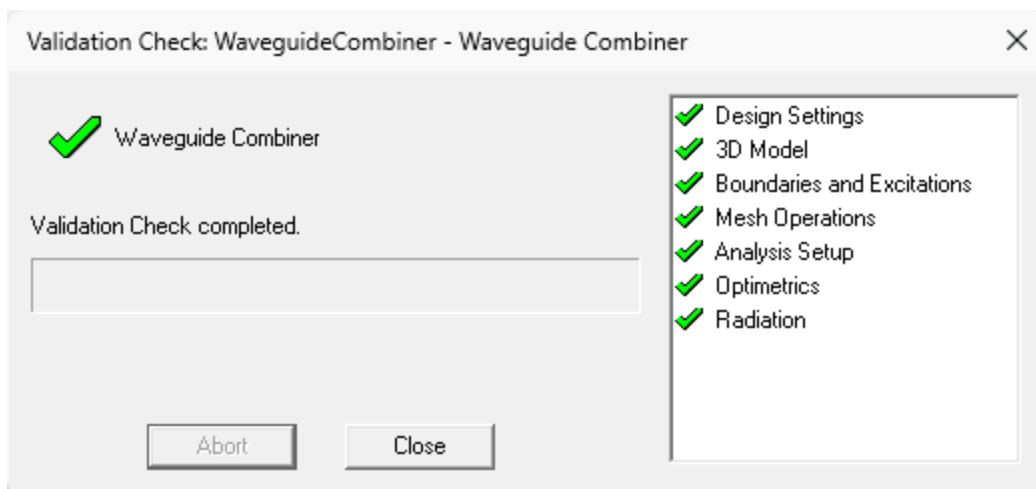

For this waveguide combiner project, a green check mark should appear next to each project step in the list.

The following icons can appear next to an item:



Indicates the step is complete.



Indicates the step is incomplete.



Indicates the step may require your attention.

3. If the validation check indicates that a step in your waveguide combiner project is incomplete or incorrect, then return to the corresponding step in HFSS and carefully review its setup.
4. Click **Close**.
5. Click **File > Save** to save any changes you may have made to your project.

## Generating the Solution

Now that you have entered all the appropriate solution criteria and validated the project setup, the waveguide combiner problem is ready to be solved.

When you set up the solution setup criteria for this model, you specified values for an adaptive analysis (Maximum number of passes and Maximum delta S per pass). An adaptive analysis is a solution process in which the mesh is refined iteratively in regions where the error is high, which increases the solution's accuracy.

The following is the general process the program carries out during an adaptive analysis:

1. HFSS generates an initial mesh.
2. Using the initial mesh, HFSS computes the electromagnetic fields that exist inside the structure when it is excited at the solution frequency. (If you are running a frequency sweep, an adaptive solution is performed only at the specified solution frequency.)
3. Based on the current finite element solution, HFSS estimates the regions of the problem domain where the exact solution has strong error. Tetrahedra in these regions are refined.
4. HFSS generates another solution using the refined mesh.
5. The software recomputes the error, and the iterative process (solve — error analysis — refine) repeats until the convergence criteria are satisfied or the requested number of adaptive passes is complete.
6. If a frequency sweep is being performed, as with this waveguide combiner problem, HFSS then solves the problem at the other frequency points without further refining the mesh.

## Analyze the Setup You Defined

Begin the solution process using any one of the following three methods:

- From the Solution ribbon tab, click  **Analyze All**. This command solves every solution setup in the design.
- Right-click **Setup1** under Analysis in the Project Manager and choose **Analyze**. This command only solves the setup that you right-clicked.
- From the menu bar, click **HFSS > Analyze All**. This command solves every solution setup in the design.

HFSS computes the 3D field solution inside the structure.

The *Progress* window displays the solution progress as it occurs:

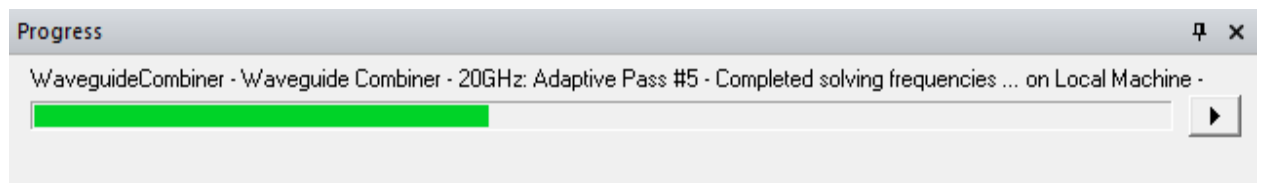

### Note:

The results that you obtain should be approximately the same as the ones given in this section. However, there may be a slight variation between platforms and between different versions of the Ansys Electronics Desktop software.

## View the Solution Data

While the analysis is running, you can view a variety of profile, convergence, and matrix data about the solution. The subsections that follow cover the available solution data.

## View the Profile Data

While the solution proceeds, examine the computing resources, or profile data, used by HFSS during the analysis.

The profile data is essentially a log of the tasks performed by HFSS during the solution. The log indicates the length of time each task took and how much RAM/disk memory was required.

To view profile data for the solution:

- From the HFSS menu, click **Results > Solution Data** or, right-click **Setup1** in the Project Manager and choose **Profile** from the shortcut menu.

The *Solution Data* dialog box appears with the *Profile* tab selected.

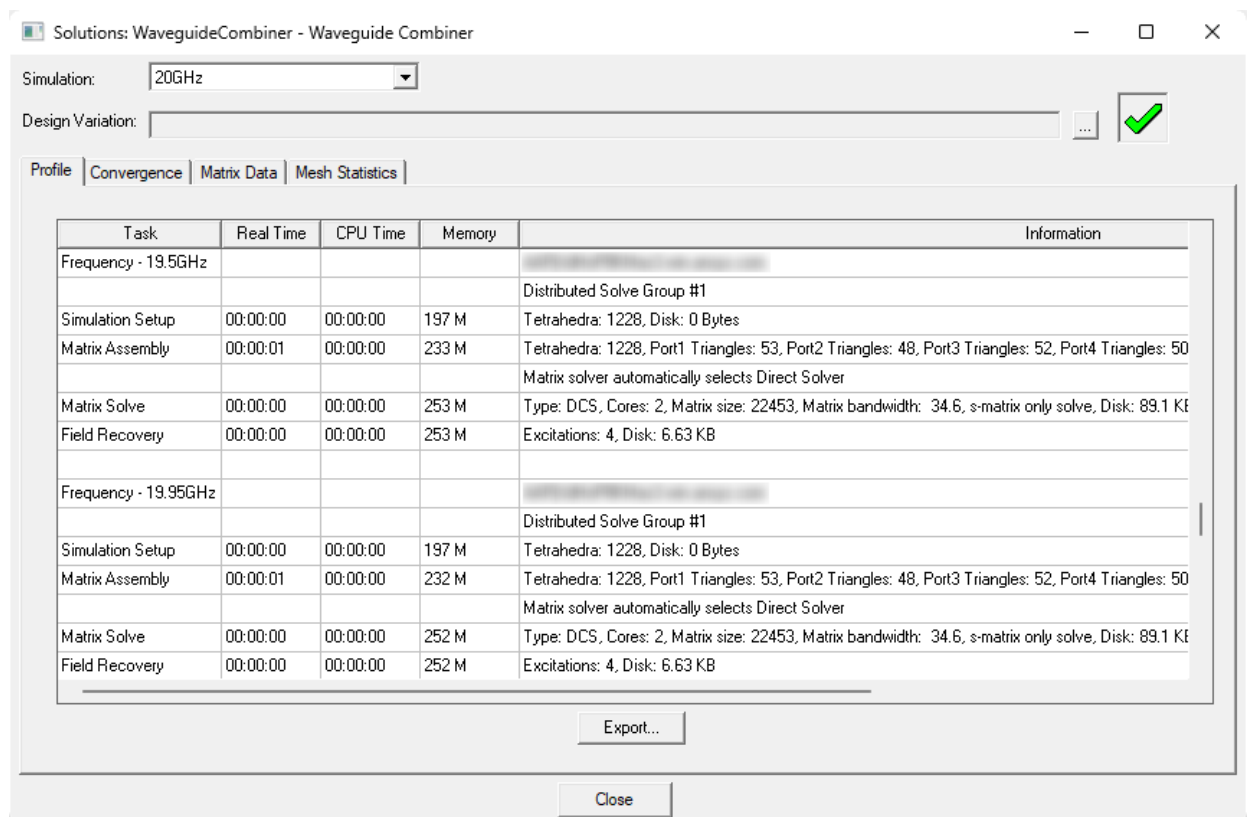

Notice in the **Simulation** drop-down menu that **Setup1** is selected as the solution setup. By default, the most recently solved solution is selected.

For the 20GHz solution setup, you can view the following profile data:

<b>Task</b>	Lists the operation performed during the solution process. For example, the task, <i>Adaptive Refine</i> , is the automatic mesh refinement operation, which is repeated until the convergence criterion is satisfied or until completion of the maximum specified number of passes.
<b>Real Time</b>	The amount of real time (clock time) required to perform the task.
<b>CPU Time</b>	The amount of CPU time required to perform the task.
<b>Memory</b>	The amount of RAM/virtual memory required of your machine to complete the task. This value includes the memory required by all applications launched for the simulation (mesher, ComEngine, solver, and so on), not just Ansys Electronics Desktop.
<b>Information</b>	Information concerning the specific task (such as the number of tetrahedra in the mesh, basis frequencies, and elapsed time).

## View the Convergence Data

To view convergence information for the solution:

- In the *Solution Data* window, click the **Convergence** tab.

The screenshot shows the **Convergence** tab in the Solution Data window. It includes the following settings and data:

- Number of Passes:** Completed 7, Maximum 15, Minimum 1.
- Max Mag. Delta S:** Target 0.005 (indicated by a red arrow), Current 0.0037335.
- View:**  Table,  Plot.
- Export...** button.
- CONVERGED** status (indicated by a red arrow).
- Consecutive Passes:** Target 1, Current 1.

Pass Number	Solved Elements	Max Mag. Delta S
1	472	N/A
2	578	0.12768
3	695	0.033034
4	763	0.011306
5	914	0.0088689
6	1018	0.0054231
7	1228	0.0037335

Based on the criteria you specified for **Setup1**, you can view the following convergence data:

- Number of adaptive passes completed and remaining.

When the solution is complete, you can view the number of adaptive passes that were performed. If the solution converged within the specified stopping criteria, fewer passes than requested may have been performed.

- Number of tetrahedra in the mesh at each adaptive pass.
- Maximum magnitude of delta S between two passes.

For solutions with ports, as in the **20GHz** setup, at any time during or after the solution process, you can view the maximum change in the magnitude of the S-parameters between two consecutive passes. This information is available after two or more passes have been completed.

The convergence data can be displayed in table format or on a rectangular (X - Y) plot.

**Note:**

You can see that the solution is *CONVERGED*. The **Max. Mag. Delta S** value at the seventh pass is less than the value specified in the setup (0.005). Had convergence not been achieved, you could have either relaxed the Max. Delta S requirement or increased the **Maximum Number of Passes**.

**View the Matrix Data**

You can view matrices computed for the S-parameters during each adaptive and sweep solution.

To view the matrices:

1. In the *Solution Data* window, click the **Matrix Data** tab.
2. In the **Simulation** drop-down menus, do the following:
  - a. Verify that **Setup1** is selected as the solution setup you want to view.
  - b. Verify that **LastAdaptive** is selected as the solved pass you want to view.
3. Select **S Matrix** as the type of matrix data you want to view.
4. Click the **Format** subtab and ensure that **Magnitude/Phase (deg)** is selected from the drop-down menu as the format for displaying the matrix information.

You can display matrix data in the following formats:

<b>Magnitude/Phase</b>	Displays the magnitude and phase of the matrix type.
<b>Real/Imaginary</b>	Displays the real and imaginary parts of the matrix type.
<b>dB/Phase</b>	Displays the magnitude in decibels and phase of the matrix type.
<b>Real</b>	Displays the real parts of the matrix type.
<b>Imaginary</b>	Displays the imaginary parts of the matrix type.
<b>Magnitude</b>	Displays the magnitude of the matrix type.
<b>Phase</b>	Displays the phase of the matrix type.
<b>dB</b>	Displays the magnitude in decibels of the matrix type.

5. Select the solved frequencies to display:
  - To display the matrix entries for all solved frequencies:
    - a. In the second **Simulation** drop-down menu, select **Sweep**.
    - b. Check **Display All Frequencies**.

- To show the matrix entries for one solved frequency:
  - a. Clear **Display All Frequencies**.
  - b. Select the solved frequency for which you want to view matrix entries.

For adaptive passes, only the solution frequency specified in the *Solution Setup* dialog box is available. For frequency sweeps, the entire frequency range is available.

The following matrix data shows the values when the frequency is 20 GHz:

Freq		S:Port1	S:Port2	S:Port3	S:Port4
20GHz	Port1	(0.025266, -119)	(0.69771, -95.7)	(0.098225, -93.6)	(0.70326, 175)
	Port2	(0.69771, -95.7)	(0.098337, 173)	(0.70326, -5.47)	(0.026226, 19.7)
	Port3	(0.098225, -93.6)	(0.70326, -5.47)	(0.02773, -118)	(0.69762, 84.3)
	Port4	(0.70326, 175)	(0.026226, 19.7)	(0.69762, 84.3)	(0.098929, 172)

### Interpreting the S-matrix data:

For convenience, we will use a simplified representation of the values. The rows represent the output port numbers (first index), and the columns represent the input port numbers (second index). For example, the cell at row 3, column 2 (S:Port3:Port2) will simply be called S32, indicating output at Port3 and input at Port2.

Due to symmetry,  $S_{12} = S_{21}$ ,  $S_{23} = S_{32}$ ,  $S_{34} = S_{43}$ , and so on.

Notice that all combinations of transmission between ports 2 or 4 and ports 1 or 3 (8 values in total) are close to 0.7, which is slightly less than the value  $\sqrt{2}/2$ . Clearly, signal transmission should be between these specific port pairs.

Furthermore, the phases of S12 and S14 (or S21 and S41) are approximately 90° apart. This angle is also true for the phases of S32 and S34 (or S23 and S43), but in the opposite direction. These values indicate that if you feed ports 2 and 4 with signals equal in magnitude but 90° apart, they will add up constructively in port 1 while canceling each other in port 3. Reverse the sign of the phase shift (-90°), and the signals will add at port 3 and cancel at port 1.

Finally, S11, S22, S33, and S44 are all small in magnitude, indicating a small return loss. Similarly, S13, S31, S24, and S42 are small in magnitude, indicating little cross-talk to the wrong port.

6. Click **Close** when done viewing the *Matrix Data*.

## 7 - Analyzing the Solution

Now, HFSS has generated a solution for the waveguide combiner problem. In general, you can display and analyze the results of a project in many different ways. You can:

- Plot field overlays — representations of basic or derived field quantities — on surfaces or objects.
- Create 2D or 3D rectangular or circular plots and data tables of S-parameters, basic and derived field quantities, and, had the waveguide combiner model emitted radiation, radiated field data.
- Plot the finite element mesh on surfaces or within 3D objects.
- Create animations of field quantities, the finite element mesh, and defined project variables.
- Scale an excitation's magnitude and modify its phase.
- Delete solution data that you do not want to store.

For this waveguide combiner problem, you will:

- Create Modal S-parameter reports.
- Create an overlay of the E-Field magnitude.
- Create an animation of the E-Field magnitude overlay.



### Time



It should take you approximately 30 minutes to work through this chapter.

## Create an S-Parameters Report of S11, S12, S13, and S14

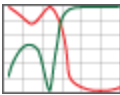
You are now ready to create the modal S-parameters reports.

1. To generate a 2D report of S11, S12, S13, S14, use one of the following three methods:
  - From the **HFSS** menu, click **Results > Create Modal Solutions Data Report > Rectangular Plot**.
  - From the **Results** ribbon tab, choose  **2D** from the  **Modal Solution Data Report** drop-down menu.
  - Right-click **Results** in the Program Manager and click **Create Modal Solutions Data Report > Rectangular Plot**.

The *Report* dialog box appears with the *Trace* tab initially selected.

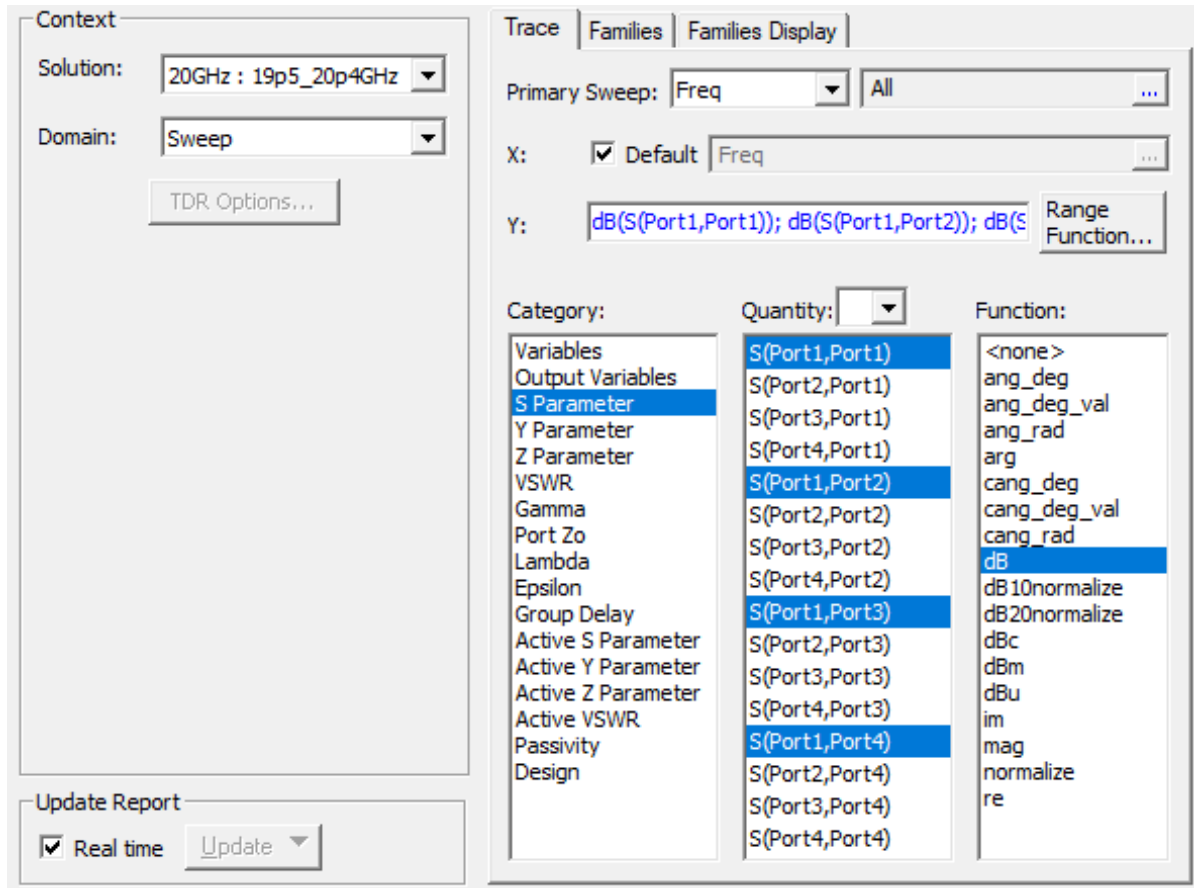

The **Context** selections are **20GHz : 19p5\_20p4** in the **Solution** drop-down menu, and **Sweep** in the **Domain** drop-down menu.

2. Select **Primary Sweep: Freq, All** and **X: Default (Freq)**, if they are not already specified.
3. In the three option lists located below the **Y** text box, specify the following information to plot along the Y-axis:

<b>Category</b>	<b>S Parameter</b>
<b>Quantity</b>	<b>S(Port1,Port1); S(Port1,Port2); S(Port1,Port3); S(Port1,Port4)</b>
<b>Function</b>	<b>dB</b>

Press and hold down **Ctrl** while clicking to select multiple items in a list.

The **Primary Sweep** option is **Freq**, which is also the default **X:** value to plot.

This option plots the sweep variables selected under the **Families** tab along the X-axis.

4. Click **New Report** and **Close**.

The function of the selected quantity is plotted against the plot domain on an XY graph.

The report window *XY Plot 1* appears, and *S Parameter Plot 1* is now listed under *Results* in the Project Manager. Each trace is also listed under *S Parameter Plot 1* (four total).

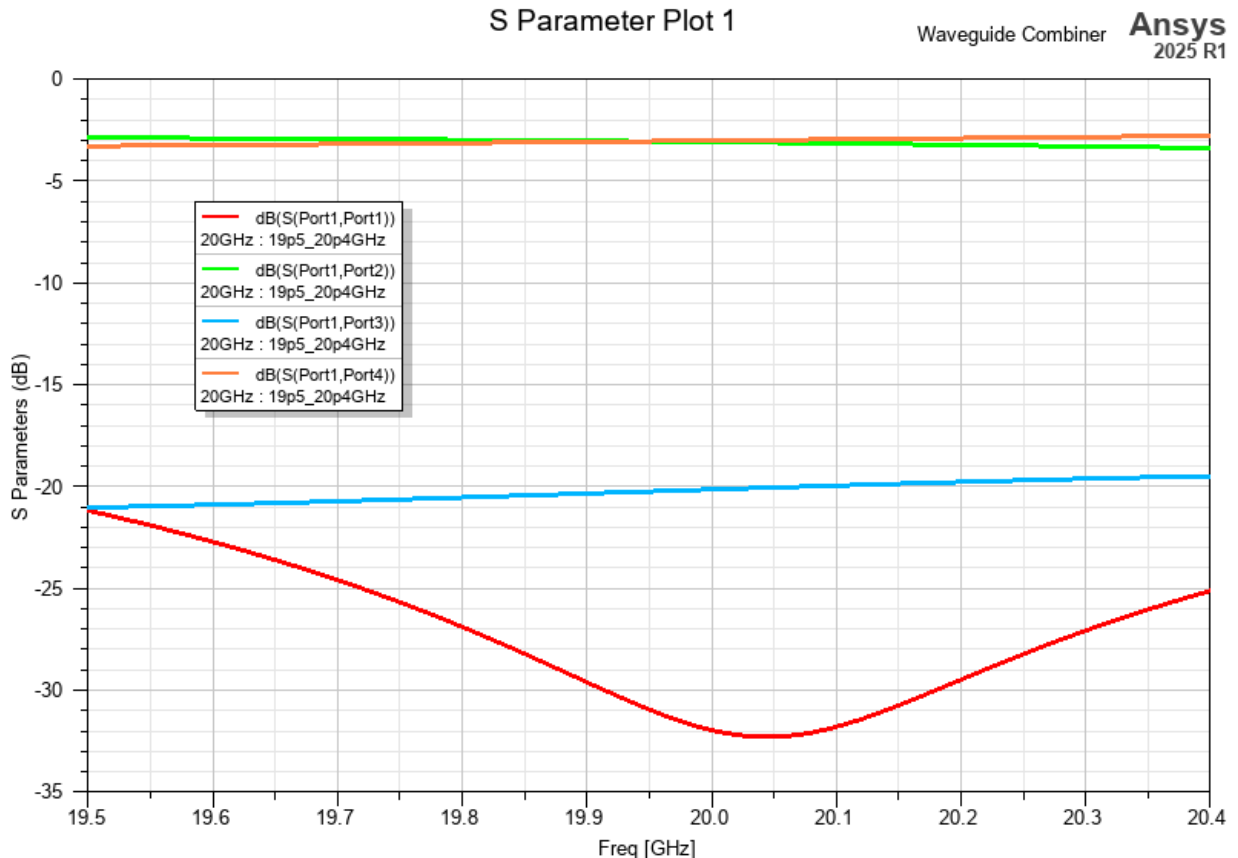



Notice that the line charted for S11 indicates that this model has its lowest return loss at about 20.04 GHz, if it were driven at Port 1.

## Create an S-Parameters Report of S12 and S14

Create a plot containing two of the four S parameters shown in the previous plot. S12 and S14 are relatively flat and close together in S Parameter Plot 1. By eliminating the other two traces, The Y scale will be automatically reduced to expand the S12 and S14 traces vertically.

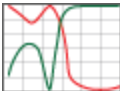
To generate a 2D plot of only S12 and S14:

- From the **Results** ribbon tab, choose  **2D** from the  **Modal Solution Data Report** drop-down menu.

The *Report* dialog box appears

The **Context** selections are **20GHz : 19p5\_20p4** in the **Solution** drop-down menu and **Sweep** in the **Domain** drop-down menu.

2. Select **Primary Sweep: Freq, All** and **X: Default (Freq)**, if they are not already specified.
3. In the three option lists located below the **Y** text box, specify the following information to plot along the Y-axis:

Category	S Parameter
Quantity	S(Port1,Port2); S(Port1,Port4)
Function	dB

4. Click **New Report** and **Close**.

The report window *S Parameter Plot 2* appears and is listed under *Results* in the Project Manager.

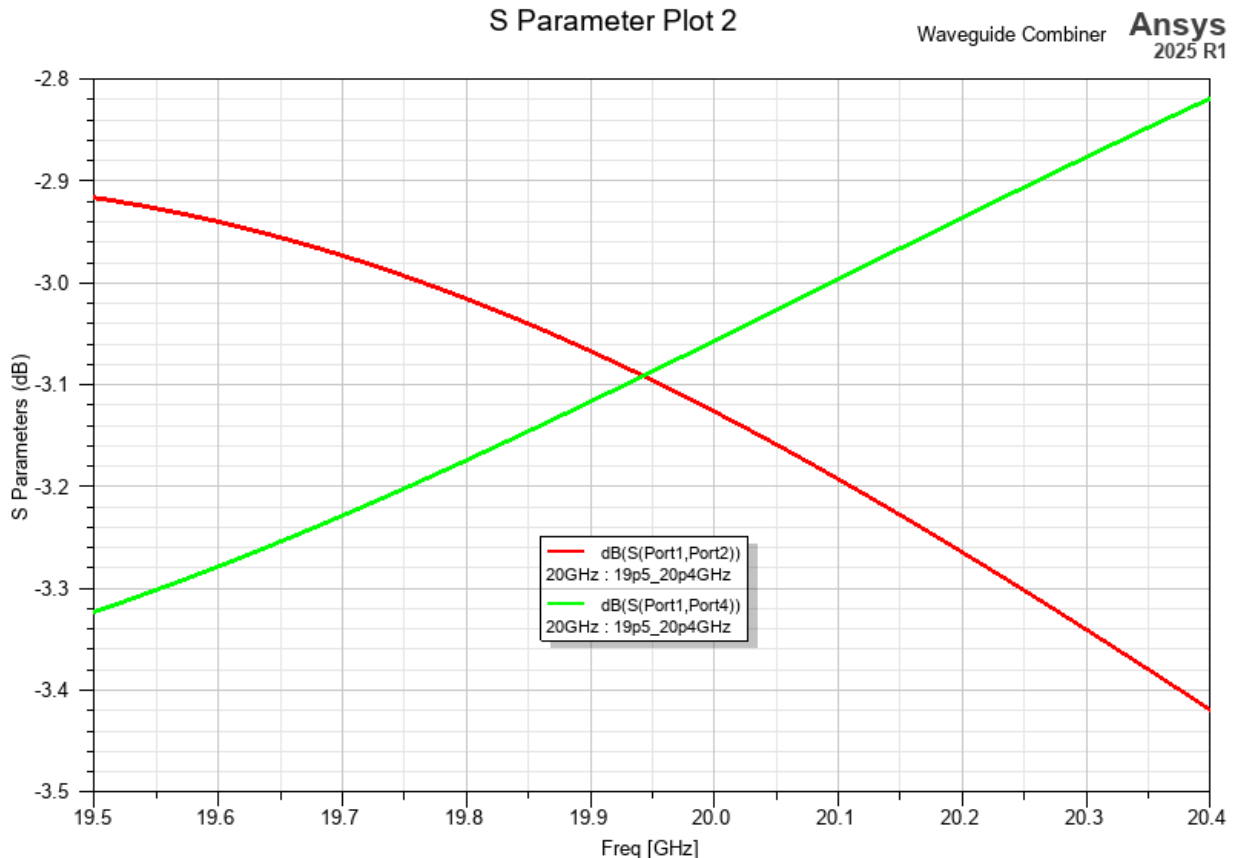

Notice the intersection of the two traces. At approximately 19.94 GHz, S12 and S14 are both about -3.09 dB ( $\approx \sqrt{2}/2$ ). These are the traces that appeared relatively flat on S

Parameter Plot 1, but the slopes are more clearly seen here with the reduced range of the Y axis.

S12 represents signal transmission between two ports on the same half of the combiner, specifically, the -Y half. In this transmission direction, the device acts like a low-pass filter, with the output signal decreasing as the frequency increases.

Conversely, S14 represents a diagonal signal path through the combiner. In this transmission direction, the device acts like a high-pass filter, with the output signal increasing as the frequency increases.

The device is clearly designed for optimal performance at close to 20 GHz, with roughly the same performance when the signal is directed to either output port.

## Scale the Magnitude and Phase for the Ports

You will soon create a field overlay plot of the magnitude of E and examine the resulting E- field pattern. But, before doing that, you must first scale the magnitude of the ports to represent equal power input to **Port2** and **Port4**, and zero at the other two ports. You must also modify the phase angle for **Port4**. As a result, these settings will make the model behave as the specific waveguide combiner that is described in this exercise.

To modify the magnitude and phase for the ports:

1. From the menu bar, click **HFSS > Fields > Edit Sources** or right-click **Field Overlays** in the Project Manager and click **Edit Sources**.

The *Edit post process sources* dialog box appears.

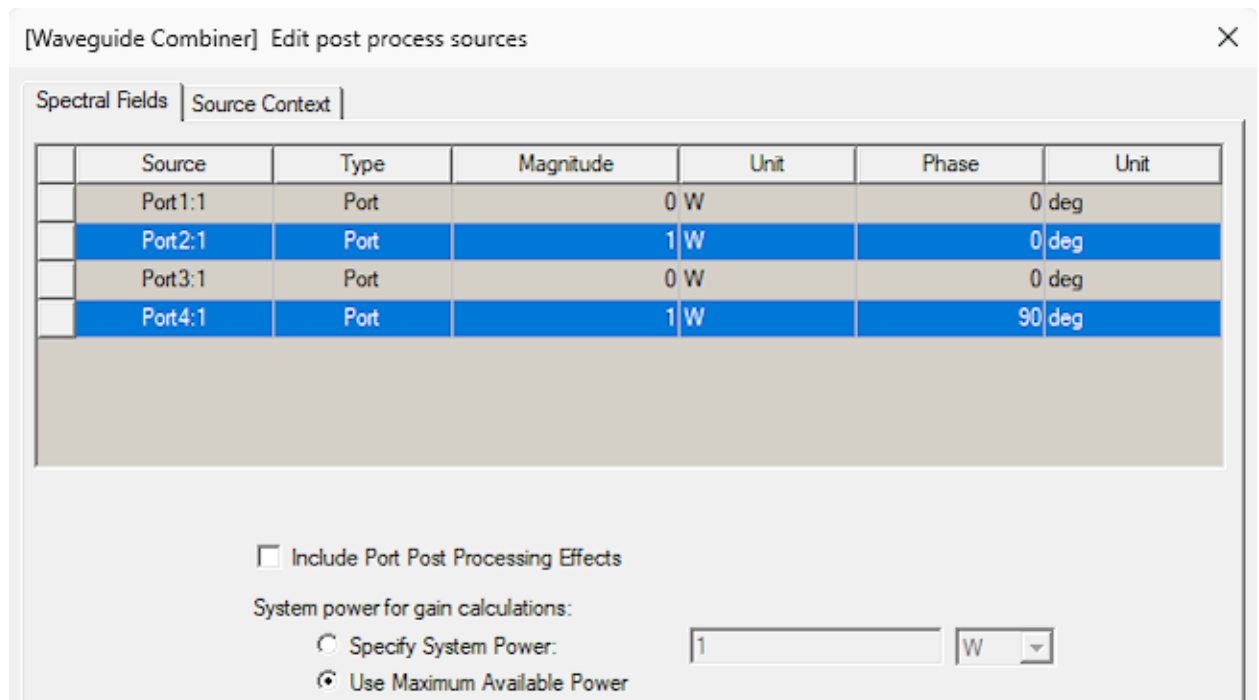

2. In the **Magnitude** text box for **Port1:1** and **Port3:1**, enter **0**.
3. In the **Magnitude** text box for **Port2:1** and **Port4:1**, enter **1**.

This magnitude is the factor by which the excitation value is scaled. **Port2:1** and **Port4:1** are each to be fed the output of a separate solid state power amplifier (SSPA).

**Note:**

Since this is a half-symmetry model of the actual waveguide combiner, the 1 W port excitations are equivalent to 2 W at each input port of the full device that the model represents.

Additionally, you may have noticed that, when you first accessed the *Edit post process sources* dialog box, the default magnitude at **Port1:1** was 0.5 (not 1). The reason is that you previously applied a symmetry boundary and, accordingly, specified a port impedance multiplier of 2. Therefore, the program decreased the source magnitude from the default value of 1 W to 0.5 W and, by default, placed the excitation at the first port. The fact that you are applying a full watt of power to each of the half-symmetry input ports is perfectly acceptable. Just be aware that whatever excitation you apply is only half of the equivalent magnitude going into the full part the model represents (due to the use of symmetry).

4. In the **Phase** text box for **Port4:1**, enter **90**.

This value is the phase of the excitation entering **Port4**, to which the output of an SSPA is fed 90 degrees out-of-phase relative to the **Port2** excitation.

5. Click **OK**.

The correct magnitude and phase are now assigned to all ports.

## Create a Mag E Field Overlay

Now that you have scaled the magnitude and phase for each port, you are ready to create a field overlay of the magnitude of E and examine the resulting E-field pattern.

1. In **Select Faces** mode (**Edit > Selection Mode > Faces**), click the top face of the **wg\_combiner** object.
2. Use one of the following three methods to begin creating the mag E field overlay:
  - On the **HFSS** menu, click **Fields > Plot Fields > E > Mag\_E**.
  - Right-click **Field Overlays** in the Project Manager and click **Plot Fields > E > Mag\_E**.
  - Right-click in the *Modeler* window and click **Plot Fields > E > Mag\_E** from the short-cut menu.

The *Create Field Plot* dialog box appears.

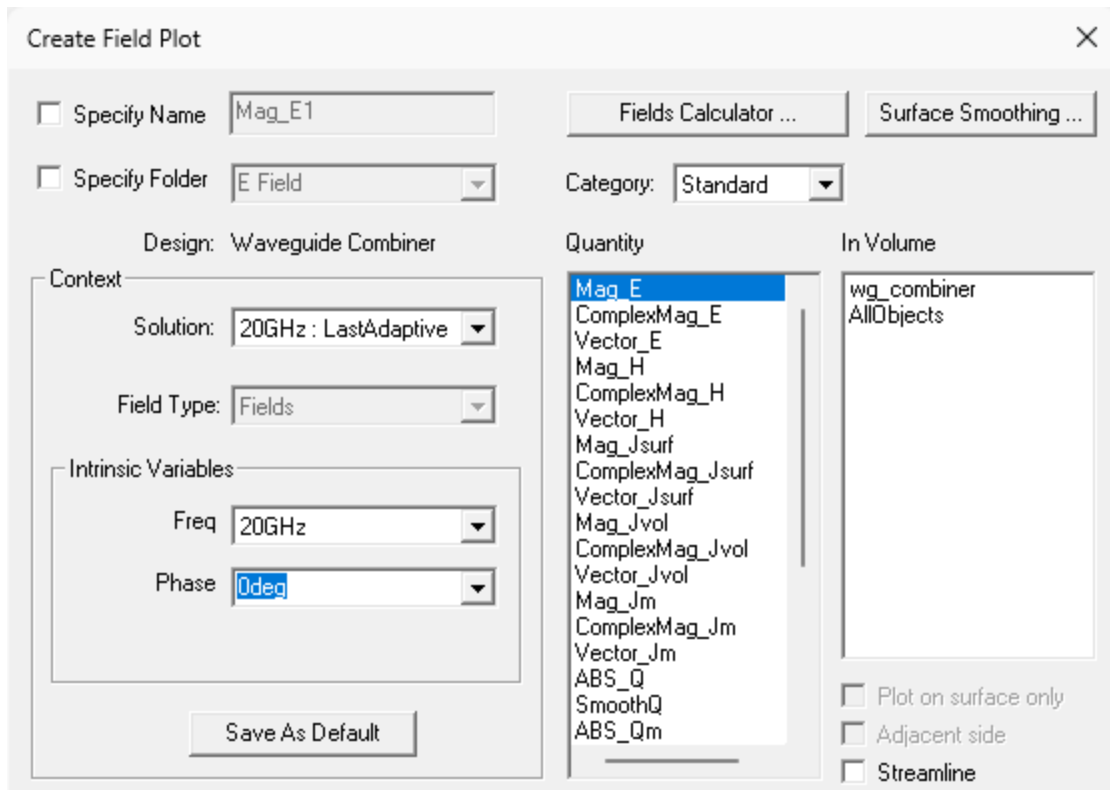

3. Select **Mag E** from the **Quantity** list.

This command overlays the magnitude of the real part of the electric field  $|\mathbf{E}|(x,y,z,t)$  as the quantity to plot.

4. Accept **Setup1: LastAdaptive** and **20 GHz** as the **Solution** and **Freq** options, respectively. In this case, these are the only available options.

The *Freq* drop-down menu includes a list of frequencies for which a field solution is available.

5. Select **0deg** from the **Phase** drop-down menu.
6. Click **Done**.

The **Mag\_E1** field overlay appears on the geometry in the *Modeler* window and is now listed under *Field Overlays* in the Project Manager.

The resultant E-field pattern shows that input from wave ports 2 and 4, with a 90-degree out-of-phase separation, combine at port 1. The E-field at port 3 is less than 80160;V/m (or less that 0.6 % of the peak E field). So, you can see that the waveguide combiner behaved as expected with a 90-degree phase angle between the two inputs.

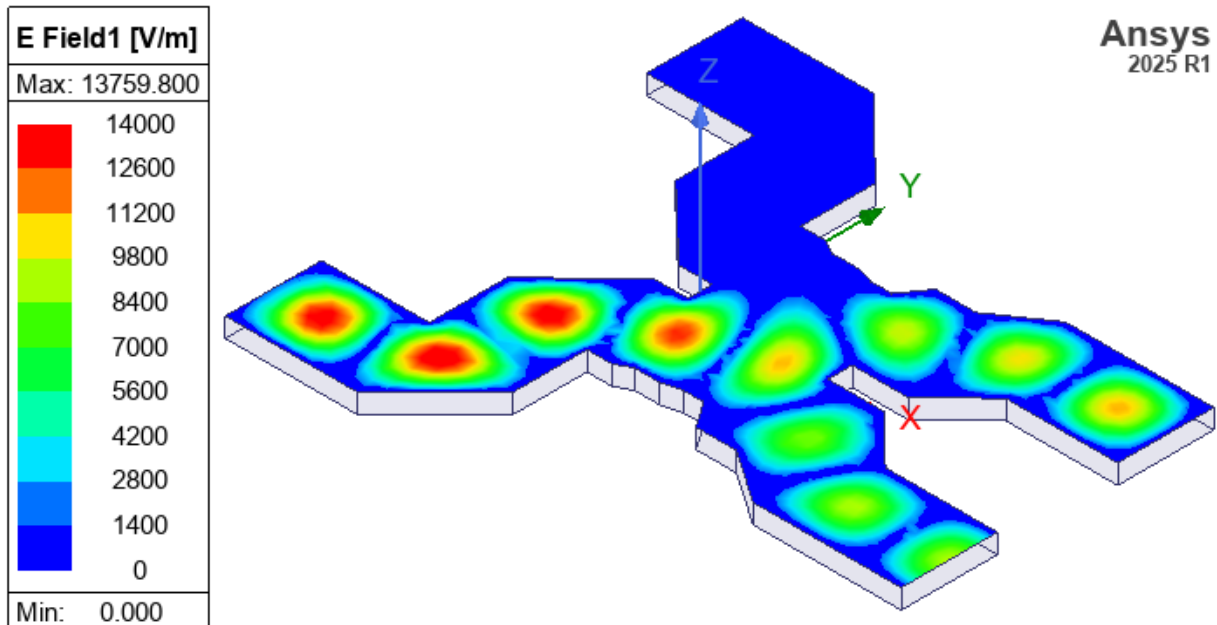
**Note:**

To better see the low-strength field results at port 3, you can double-click the overlay legend and adjust the parameters in the *Scale* tab of the dialog box that appears. For example, you could switch to a **Log** plot. Alternatively, select **Use Limits** and specify a lower **Max** value to bring out the contour colors in the port 3 waveguide section. For a *Linear* scale, try a *Max* value in the 70 to 500 range. Of course, doing this will cause the fields in the port 1, 2, and 4 waveguide sections to be saturated red.

## Create a Phase Animation of the Mag E Overlay

Next, you will create an animation of the E-field magnitude overlay to examine a frame-by-frame animated behavior field.

To create a phase animation of the Mag E plot:

1. Select the **Mag\_E1** field overlay plot under *Field Overlays* > *E Field* in the Project Manager.
2. Click **HFSS** > **Fields** > **Animate**.

The *Select Animation* dialog box appears.

3. Click **New**.

The *Setup Animation* dialog box appears.

4. Accept the default name **Animation1** in the **Name** text box.
5. Optionally, type a description of the animation in the **Description** text box.
6. Under the **Swept Variable** tab, select **Phase** from the **Swept variable** list.
7. Accept the remaining default settings.
8. Click **OK**.

The animation begins in the *Modeler* window.

The *Animation* panel appears in the upper-left corner of the desktop, enabling you to stop, restart, reverse, and control the speed of the frames.

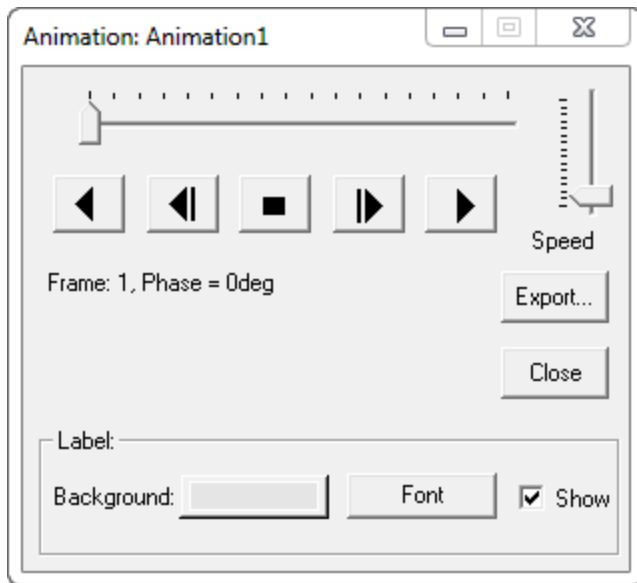

Your animation includes a Phase angle annotation and should look like the following image:

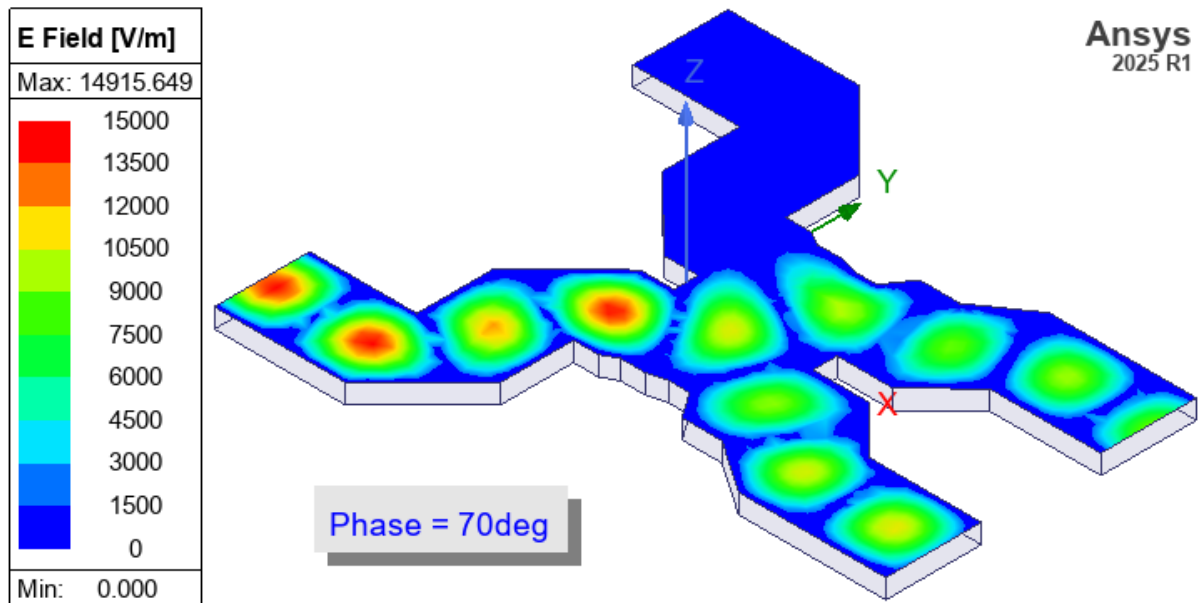

## Self-Study Challenge

You may wish to experiment with different phase angles for the excitation at **Port4**. For example, you could try an angle of 45 degrees, which should produce output at both **Port1** and **Port3**, with the latter having the weaker field. At a phase angle of zero, the output at each port should be equal. Finally, at a phase angle of  $-90^\circ$ , all of the output should go to **Port3**, with the field at **Port1** being insignificant.

To adjust the phase angle at **Port4**, edit the port sources as described on the page, [Scale the Magnitude and Phase for the Ports](#). Simply adjust the angle specified in step 4 of that page. You can keep the animation running and keep the *Edit post process sources* dialog box open while applying different phase angles. When you click **Apply**, the animation will be updated immediately and will continue to play.

## 8 - Optionally, Restore Legacy View Orientations

You have completed this getting started guide.

The current view orientation scheme implemented in version 2024 R1 of the Ansys Electronics Desktop application has a few of advantages over the legacy scheme:

- It is more consistent with the majority of Z-up solid modeling software products.
- The identification of front, back, left, and right sides is more intuitive.
- It is better suited to mixed 2D (typically XY) and 3D modeling, with the X axis to the right for Top, Front, Bottom, and Isometric views. Accordingly, the Right side view is the +X side of the geometry now (which was the +Y side for the legacy orientation).

However, many of the HFSS getting started guides, and those for other design types, were written using older software versions. The instructions and images in many of these guides have not been updated to the new orientation scheme. You may be working through multiple guides, or you may have a library of many models constructed in a way that is suitable for legacy orientations but perhaps not as suitable for the current orientation scheme. If so, it might be more convenient for you to select the *Use Legacy View Orientation* option.

If you prefer to continue using the legacy view orientations that were applicable to 2023 R2 and earlier versions of the Ansys Electronics Desktop application, select the option as follows:

1. From the menu bar, click **View > Options**.

The *3D UI Options* dialog box appears.

2. Select **Enable Legacy View Orientation**:

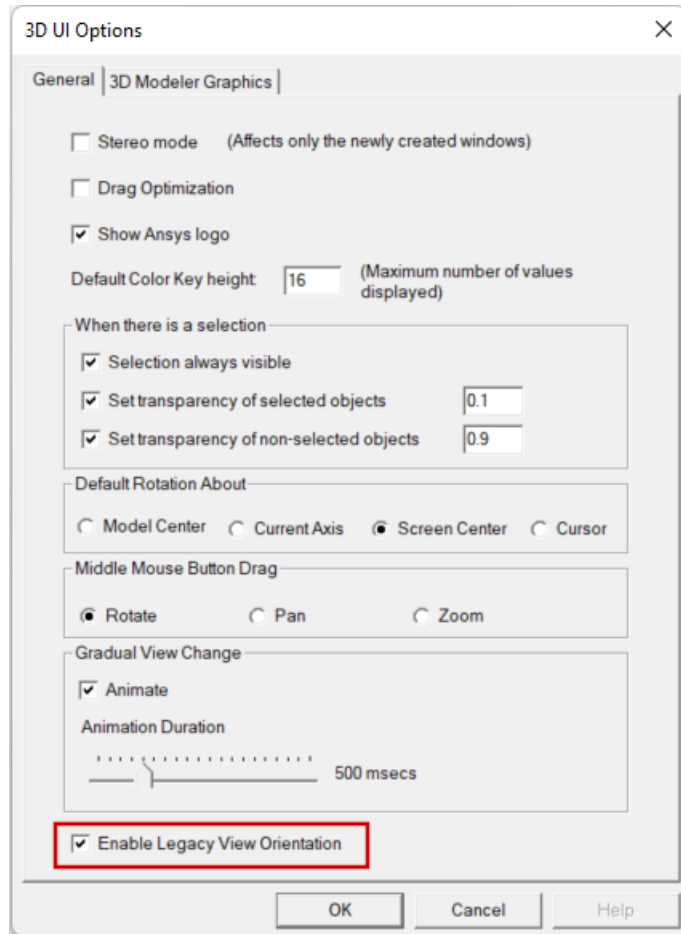

3. Click **OK**.

Otherwise, leave this option cleared to continue using the newer view orientations going forward.

The settings in the 3D UI Options dialog box are global. Your choice is retained for all future program sessions, projects, and design types that use the 3D Modeler or that produce 3D plots of results.

You can now save and close this project.